



# Overhead Concealed Swing Door Systems GT 300-350-8300-8350

## Quick Set-Up and Parts Guide

P/N C-00175 Rev 8-10-16

Nabco Entrances Inc. S82 W18717 Gemini Drive Muskego, Wisconsin 53150

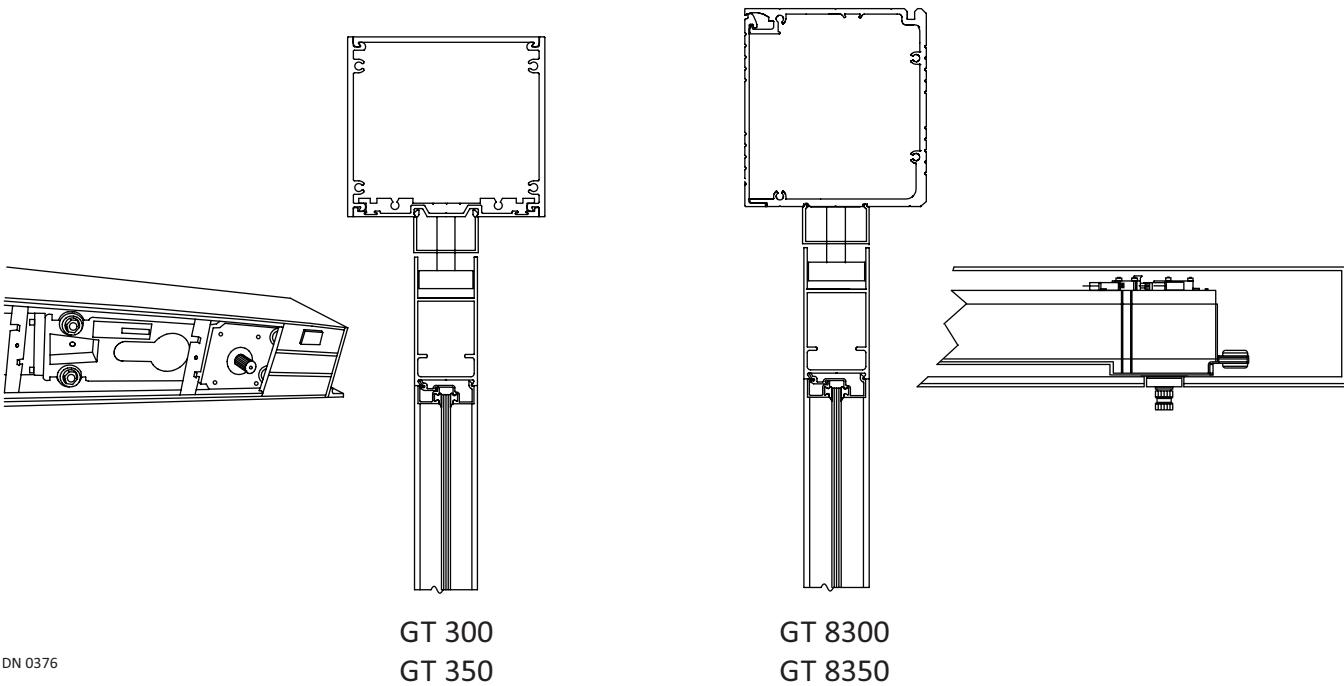
Phone: (877) 622-2694 Fax: (888) 679-3319 www.nabcoentrances.com

This document is meant to serve as a Quick Set-Up and Parts Guide only.  
Installation manuals referenced below should be downloaded and reviewed for complete installation instructions.

*Associated Manuals Part Numbers: Opus Control Wiring and Programming Manual; P/N C-00139  
Analog Control Wiring and Adjustment Manual; P/N 15-10745  
Overhead Concealed Hardware Installation Manual with Opus Control; P/N C-00184  
Swing Door Owners Manual; P/N C-00110 (for Decal Installation)  
NABCO Price Book; P/N 16-9244-30 (for Sensors, Switches, and Accessories)*

### WARNING

- Turn OFF all power to the Automatic Door if a Safety System is not working.
- Instruct the Owner to keep all power turned OFF until corrective action can be achieved by a NABCO trained technician. Failure to follow these practices may result in serious consequences.
- NEVER leave a Door operating without all Safety detection systems operational.



DN 0376

## ***Table of Contents***

<b>SECTION 1: TO THE INSTALLER</b> .....	<b>3</b>
<b>SECTION 2: ASSEMBLE THE DOOR FRAME</b> .....	<b>3</b>
<b>SECTION 3: INSTALL THE FRAME TO BUILDING</b> .....	<b>6</b>
<b>SECTION 4: INSTALL BOTTOM LOAD COMPONENTS</b> .....	<b>7</b>
<b>SECTION 5: 120 VAC GENERAL WIRING</b> .....	<b>9</b>
<b>SECTION 6: HANDING</b> .....	<b>10</b>
<b>SECTION 7: INSTALL THE FLOOR PIVOT</b> .....	<b>11</b>
<b>SECTION 8: LAY DOWN THE SADDLE THRESHOLD OVER THE FLOOR PIVOT</b> .....	<b>12</b>
<b>SECTION 9: INSTALL THE SWING DOOR (PROVIDED BY NABCO)</b> .....	<b>13</b>
<b>SECTION 10: INSTALL THE SWING DOOR (NOT PROVIDED BY NABCO)</b> .....	<b>14</b>
<b>SECTION 11: PERMANENTLY INSTALL THE SADDLE THRESHOLD</b> .....	<b>19</b>
<b>SECTION 12: INSTALL THE SWING ARM</b> .....	<b>19</b>
<b>SERVICE PARTS: BAG P/N A-00565</b> .....	<b>22</b>
<b>SERVICE PARTS: BAG P/N 21-3561</b> .....	<b>22</b>
<b>SERVICE PARTS: BAG P/N 21-0928</b> .....	<b>23</b>
<b>SERVICE PARTS: BAG P/N 21-5106</b> .....	<b>23</b>
<b>SERVICE PARTS: OHC OPUS BOTTOM LOAD HEADER</b> .....	<b>24</b>
<b>SERVICE PARTS: OHC ANALOG BOTTOM LOAD HEADER</b> .....	<b>27</b>
<b>SERVICE PARTS: OHC OPUS SIDE LOAD HEADER</b> .....	<b>30</b>
<b>SERVICE PARTS: OHC ANALOG SIDE LOAD HEADER</b> .....	<b>33</b>
<b>SERVICE PARTS: OHC SWING DOOR</b> .....	<b>36</b>

## SECTION 1: TO THE INSTALLER

The purpose of this manual is to familiarize the installer and purchaser with the proper installation and operation of this system. It is essential that this equipment be properly installed and operational before the door is used by the public. It is the installer's responsibility to inspect the operation of the entrance system to be sure it complies with any applicable standards. In the United States, ANSI Standard 156.10 (Used to cover Full Energy doors) and ANSI Standard 156.19 (Used to cover Low Energy doors) apply. Other local standards or codes may apply. Use them in addition to the ANSI standards.

The owner should determine the door is operating properly and should immediately call for service if there is any malfunction. All installation changes and adjustments must be made by qualified, NABCO trained technicians.

The OHC Header assembly can be purchased as a standalone unit and may be installed on other makes of doors and frames in lieu of the NABCO Complete Swing Door System.

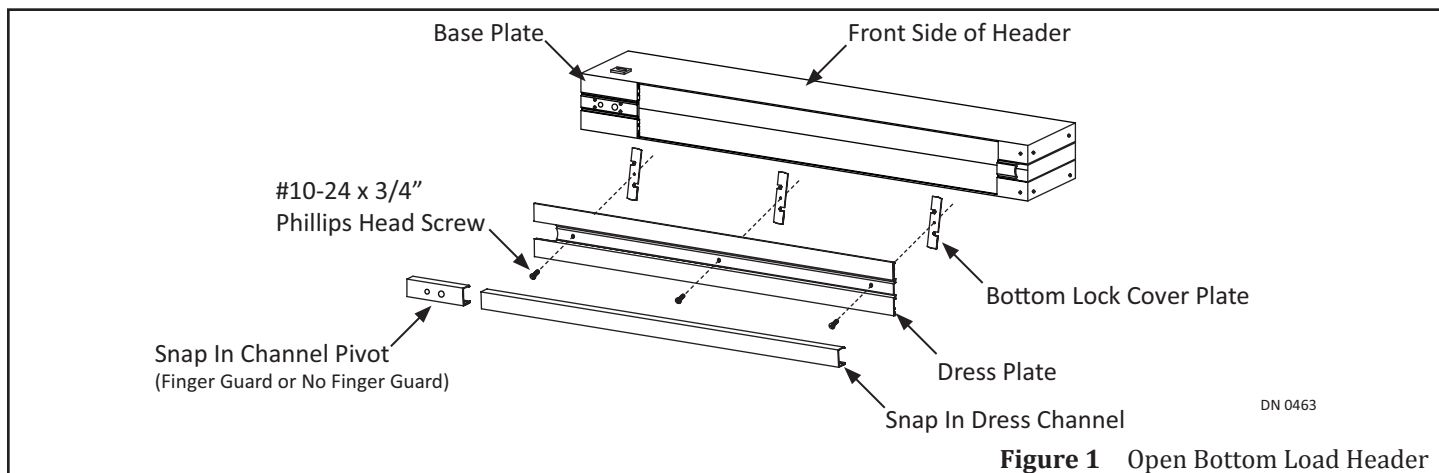
The GT-300, GT-8300, GT-350 and GT-8350 OHC swing door series is designed inline with the frame as a concealed unit. The door function is operated by the Opus Control (Standard) or by the Analog Control (Optional).

## SECTION 2: ASSEMBLE THE DOOR FRAME

### 2.1 Prep the Bottom Load Header

***FOR SIDE LOAD HEADER SKIP TO  
SUBSECTION 2.2***

1. Place Header on flat surface with Bottom facing up. Protect Header from scratches.
2. Remove #10-24 x 3/4 inch screws and Dress Plate. Set aside.
3. Mark the locations of each Lock Cover Plate to ensure it is reinstalled in the correct position.
4. Remove Lock Cover Plates. Set Aside.
5. Remove boxes and/or parts bags from inside Header. Set aside.

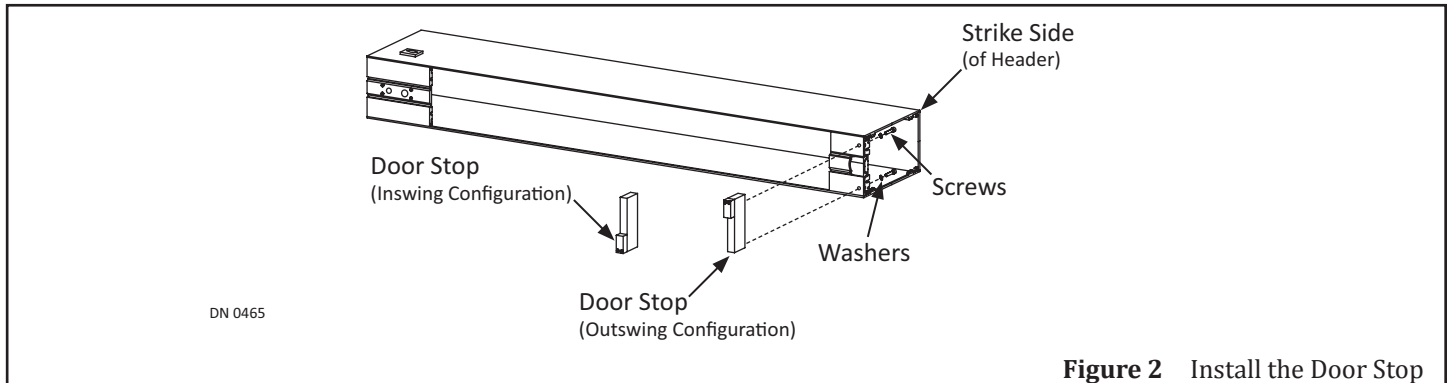


#### 2.1.1 Install the Door Stop (Standard)

***FOR PANIC LATCH SKIP TO  
SUBSECTION 2.1.2***

Door Stops are standard and can be installed on an Inswing door and an Outswing door. A Door Stop is used to stop the door from swinging farther back from the fully closed position.

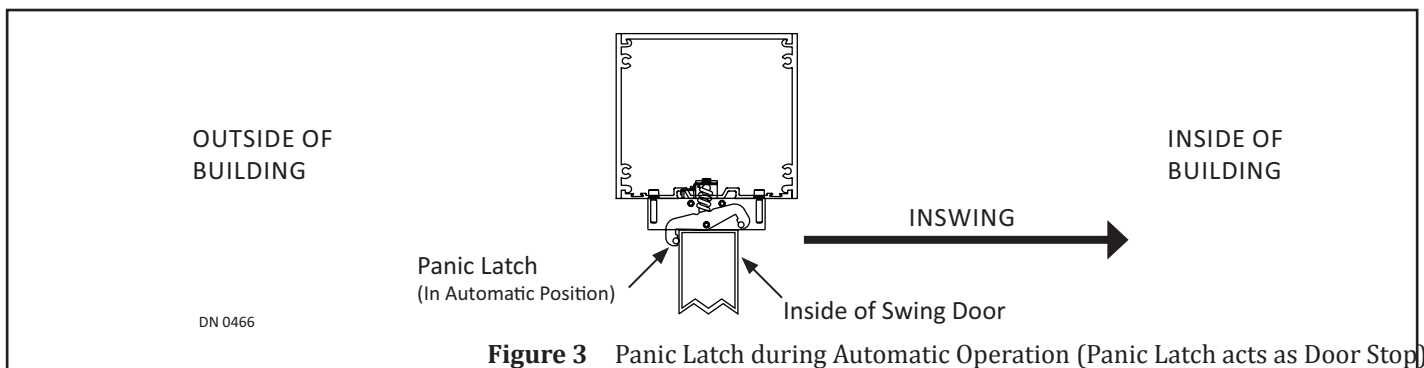
1. Obtain the Door Stop.
2. Remove (4) Socket Head Cap Screws and (4) Washers. Set aside.
3. Go to the bottom, Pivot side of Header. Butt the Door Stop against the underside of the 3-1/4 inch Strike Base.
  - ▶ For an Outswing, the Stop end of Door Stop must face front side of Header.
  - ▶ For an Inswing, the Stop end of Door Stop must face back side of Header.
4. Secure Door Stop from inside Header with (2) Socket Head Cap Screws and (2) Washers.



**Figure 2** Install the Door Stop

### 2.1.2 Install the Panic Latch (Inswing Doors)

During Automatic Operation, the Inswing door opens to the Interior side of the building/room. The Panic Latch is then used as a Door Stop. The Panic Latch is installed on Inswing doors only.

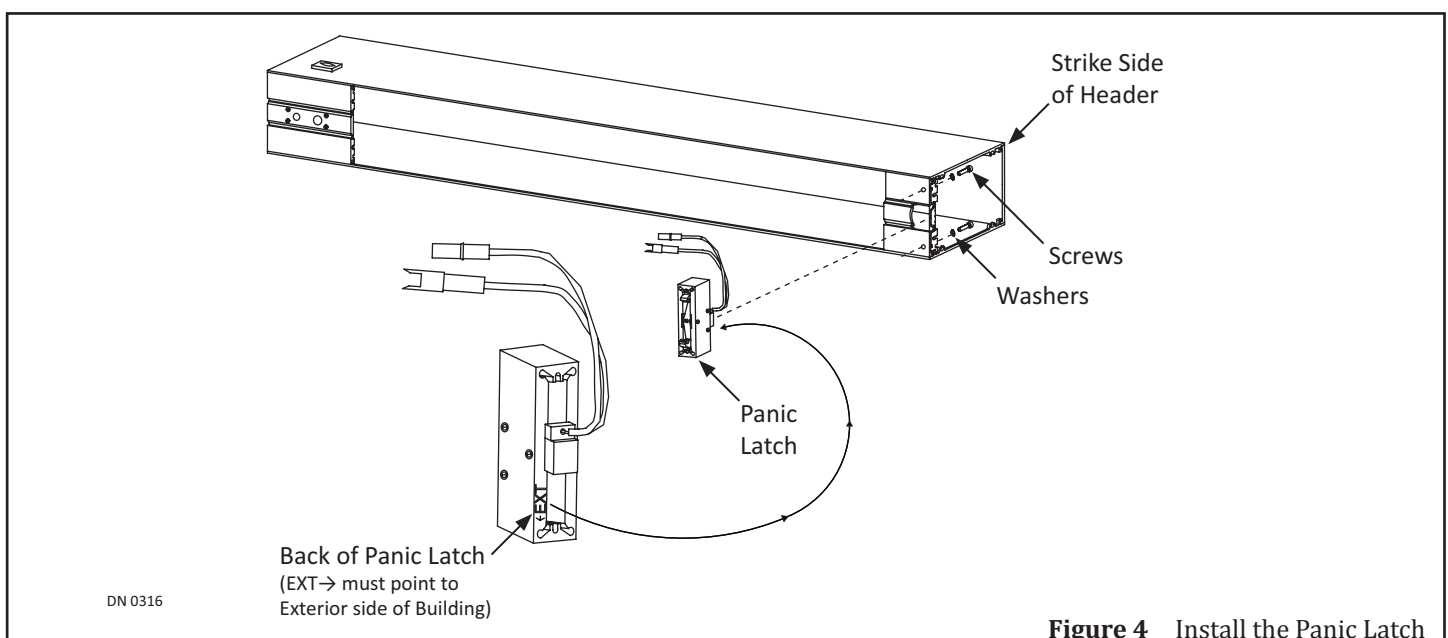


**Figure 3** Panic Latch during Automatic Operation (Panic Latch acts as Door Stop)

During Emergency Operation, the Inswing door is manually pushed Out to the exterior side of the building/room (not to exceed 50 pounds of pressure; per ANSI code). The Panic Latch flips to allow emergency egress and immediately shuts the Swing door OFF.

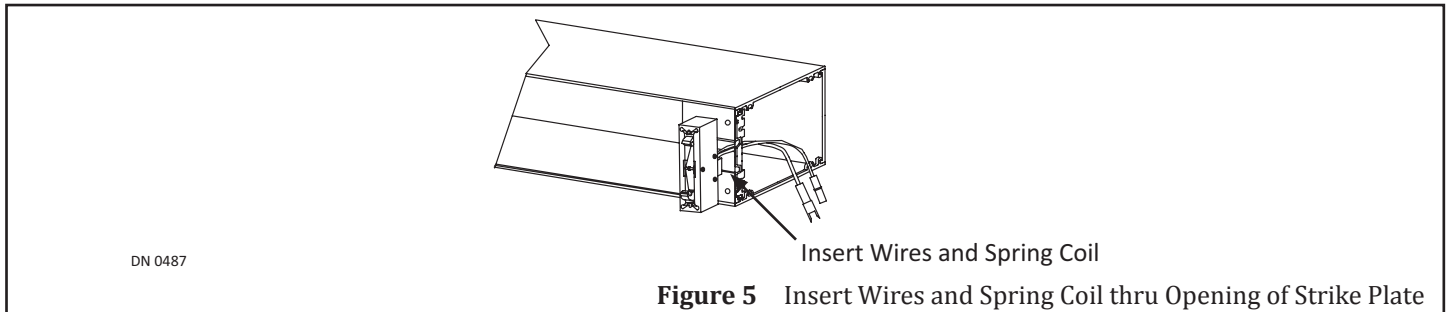
*Note: For wiring instructions please refer to P/N 15-4572 Panic Breakout Latch Wiring Installation Instructions Manual.*

1. Obtain the Panic Latch and (1) Decal. Set the Decal aside with all other Decals that were packed within Header.
2. Remove (4) Socket Head Cap Screws and (4) Washers. Set aside.
3. Turn the Panic Latch so the (EXT→) (exit arrow) points to the Exterior side of the Building.
  - a. Failure to do so, will install the Panic Latch backwards.



**Figure 4** Install the Panic Latch

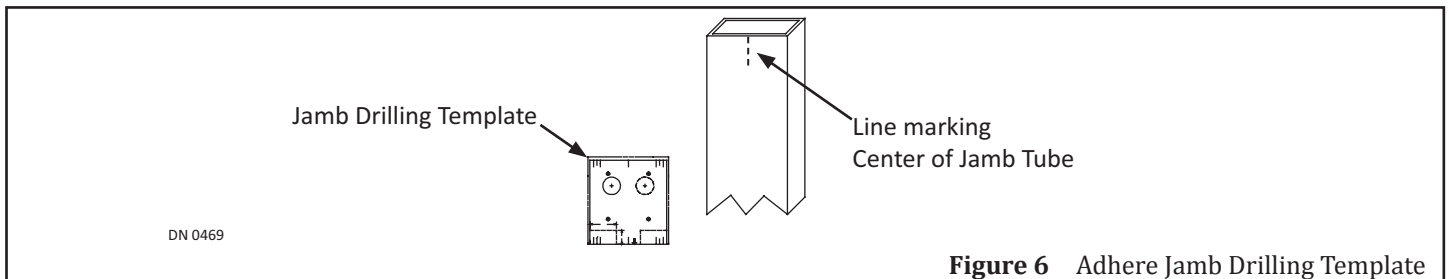
4. Go to the bottom, Strike side of Header.
5. Insert the Panic Latch wires and spring coil into the opening until the Panic Latch butts up against the Header.



6. Secure the Panic Latch from inside the Header with (2) Socket Head Cap Screws and (2) Washers.
  - a. Do Not wire or test the Panic Latch at this time.

## 2.2 Prep the Jamb Tubes

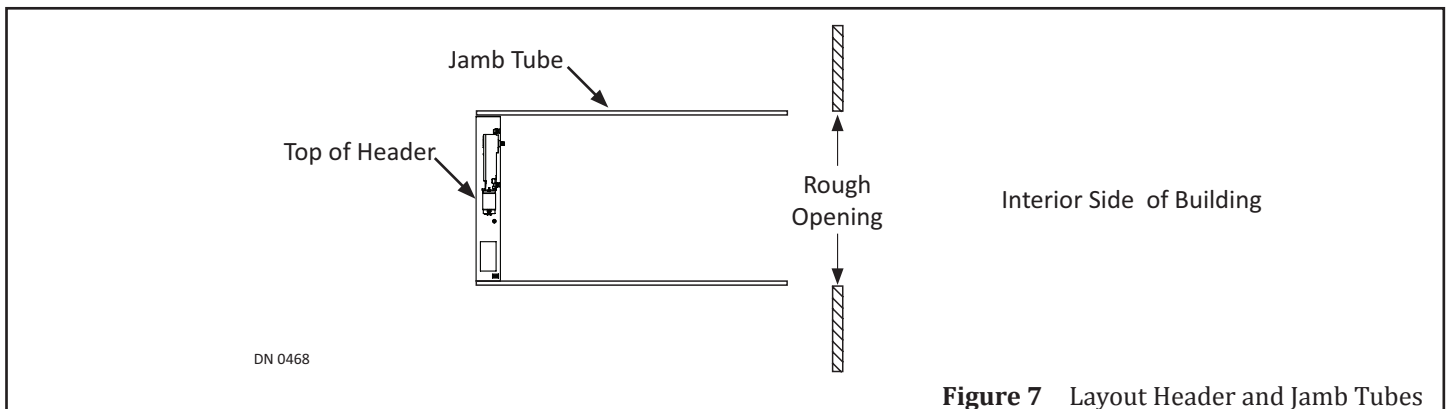
1. Measure the full height of existing Swing door.
2. Obtain (1) Jamb Drilling Template provided by NABCO.
3. Place the Jamb Drilling Template at the top of Jamb Tube so it is flush. Align the center to the previously drawn center mark.
4. Adhere the Jamb Drilling Template to each Jamb Tube. Please see Figure 8-1.
  - a. The Jamb Drilling Template is removable



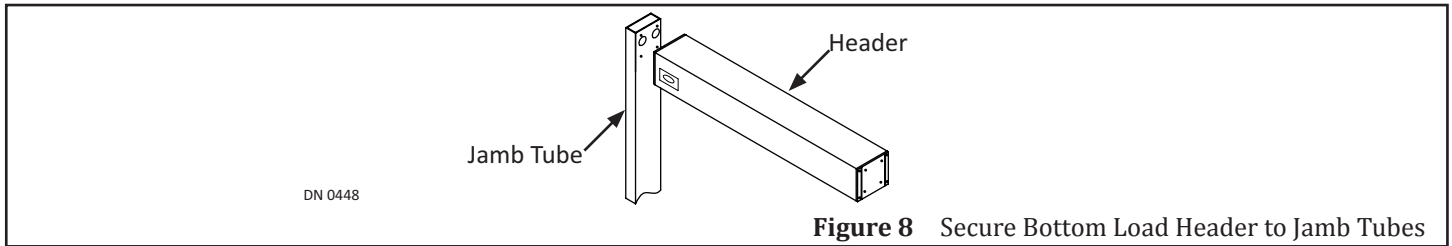
5. Drill (4) .391 diameter holes through (4) clearly marked (A)s on the Template. Countersink each screw hole.
6. Obtain (4) Rivnuts provided by NABCO. Install (1) Rivnut into each drilled .391 hole.
7. Drill (1) 1-1/4 inch diameter hole through (1 of 2) clearly marked (B)s on the Template to allow incoming 120 VAC Power.
  - a. The 120 VAC incoming power must be routed through the Strike Jamb, only.
8. Remove the Template from the Strike Jamb, then adhere same Template to the Pivot Jamb. Repeat steps.

## 2.3 Install the Header to Jamb Tubes

1. Determine which Jamb tube is the Pivot Jamb and the Strike Jamb.
  - ▶ Swing door pivots on side of Pivot Jamb.
  - ▶ Swing door locks on side of Strike Jamb.
2. Position each Jamb tube at both sides of the Header. Be sure to orientate the frame in relation to the outside of building/room.



- Secure Header to both Jamb Tubes with (8) 1/4-20 x 3/4 inch Hex Head Cap Screws and (8) 1/4 inch Star Washers from the Parts bag provided within the Header.

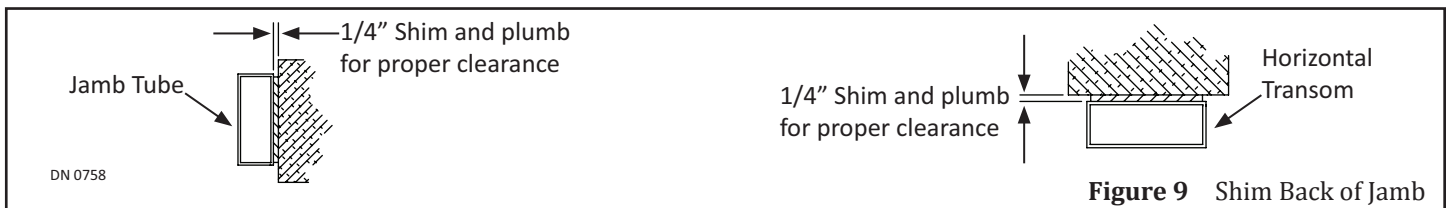


**SECTION 3: INSTALL THE FRAME TO BUILDING**

- Lift to position the assembled Frame into the rough opening. Insert all incoming wiring through the 1-1/4 inch hole located on the Strike side of Header.

*Note: Incoming 120 VAC Power wires must be pulled through the Strike end of Header for a single Swing door or the middle of Header for a simultaneous pair Swing door. It is recommended to install wires into an Electrical conduit.*

- Plumb Jamb tubes in both planes to ensure the rough opening allows a 1/4 inch clearance. Shim back of Jamb as required.

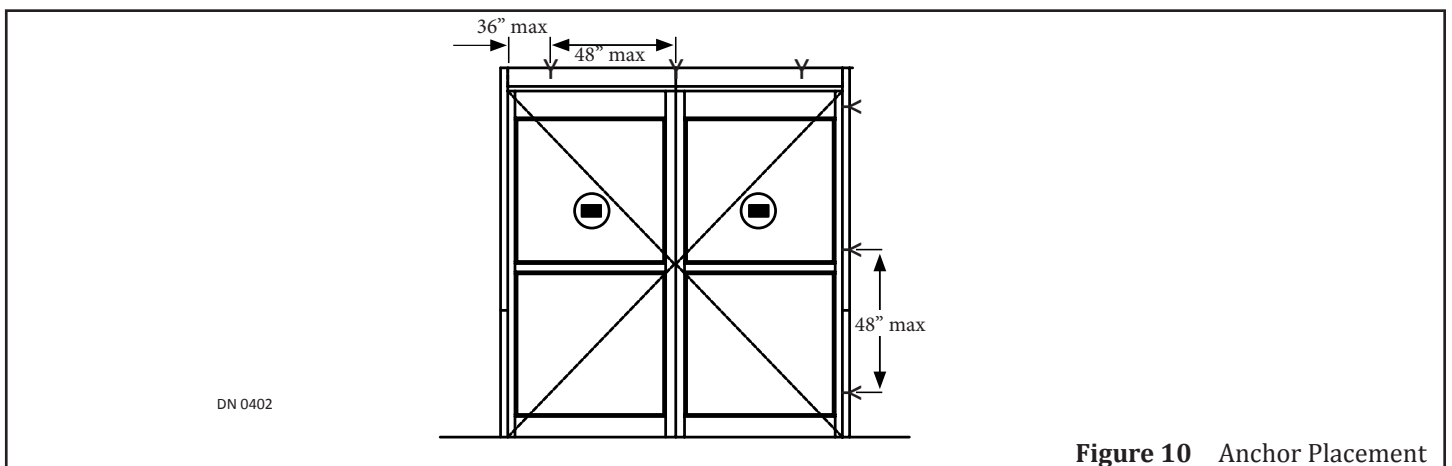


- Plumb the Header at the top to ensure the rough opening allows a 1/4 inch clearance. Shim top of Header as required.

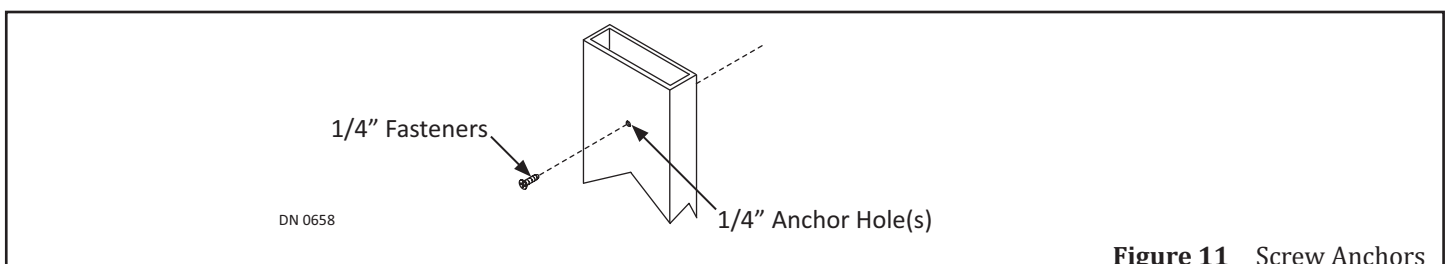
*Note: It is recommended to countersink holes as required to flush the surface.*

*Note: It is recommended to drill tap threads for anchors in a steel or aluminum structure.*

Use 1/4 inch diameter anchors with a minimum of 3 per Jamb Tube, maximum is 48 inches on center. Drill 1/4 inch diameter holes in the face of Jamb and then countersink each hole. Anchors and Fasteners must be appropriate for the type of structure being fastened into. Anchors and Fasteners are not provided by NABCO.



- Secure the Frame with Fasteners not provided by NABCO.

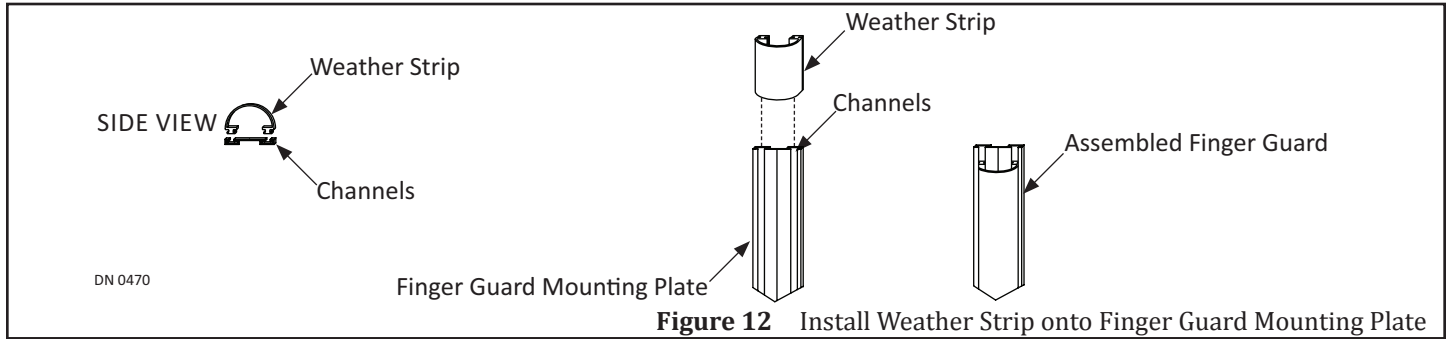


### 3.1 Install the Finger Guard

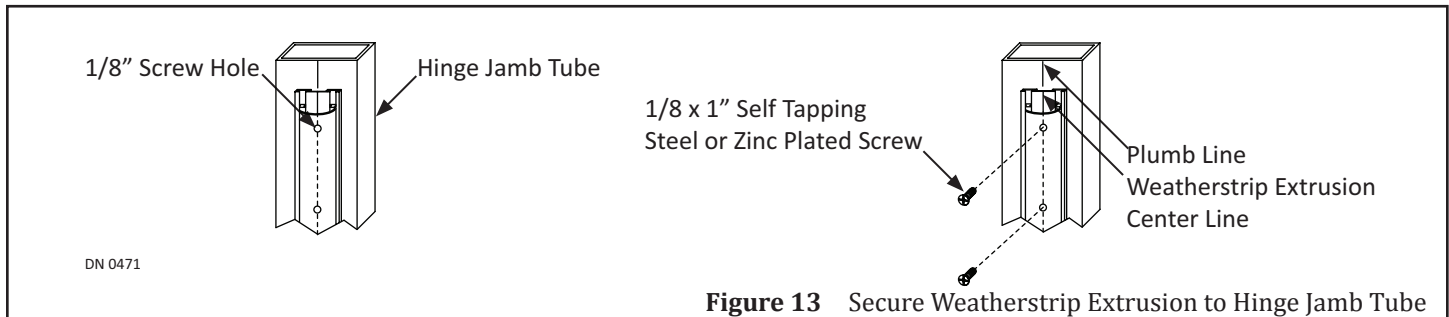
*Note: Screws must be appropriate for the type of structure being fastened into. Screws are not provided by NABCO.*

*Note: Do not overtighten screws to prevent deforming Weatherstrip Extrusion. Ensure each screw is flush to the Jamb tube.*

1. Go to the top of the Pivot Jamb tube, at the center, drop a Plumb Line to the floor.
2. Mark the Center line on the inside face of the Pivot Jamb Tube. It is recommended to use a level.
3. Insert the Weather Strip into both channels located on the Finger Guard Mounting Plate.
  - a. Spraying silicone (not included) inside the Channels may ease the insertion of the Weather Strip.



4. Line up the Center Notch located down the full length of the Finger Guard Mounting Plate, with the Center Mark located on the Pivot Jamb Tube. It is recommended to use a level.

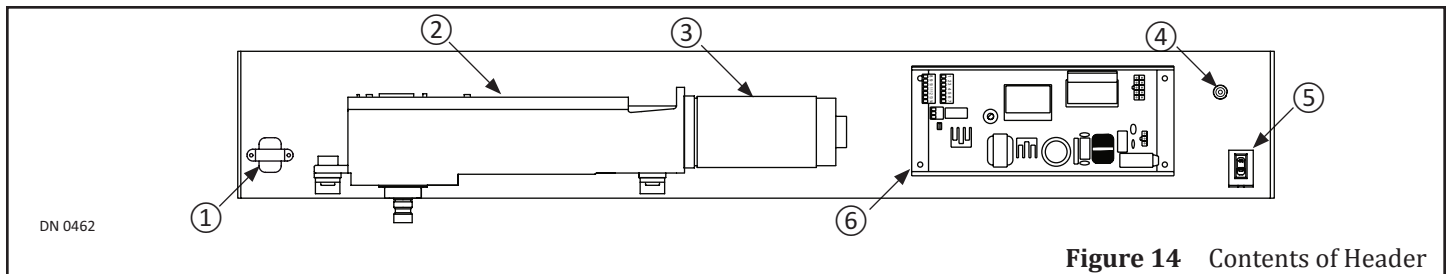


5. Drill (3-4) 1/4 inch evenly spaced screw holes down the Finger Guard Assembly.
  - a. Each screw hole must go through the Weather Strip, Mounting Plate and the Pivot Jamb Tube.
6. Secure the Finger Guard Mounting Plate onto the Pivot Jamb with 1/4 x 1 inch self tapping Screws (zinc or steel plated).

## SECTION 4: INSTALL BOTTOM LOAD COMPONENTS

**FOR SIDE LOAD HEADER SKIP TO SECTION 5**

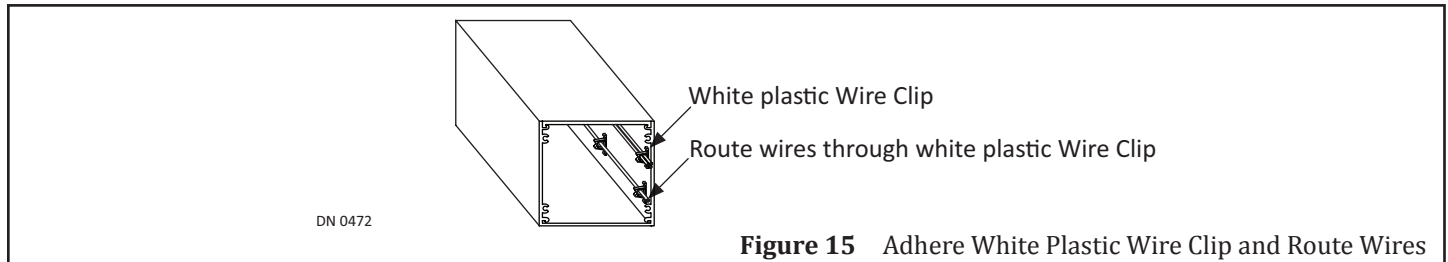
*Note: Location of Contents within Header are subject to change according to Swing door specifications.*



- |                           |                 |
|---------------------------|-----------------|
| 1. Transformer (Optional) | 4. Ground Screw |
| 2. Operator               | 5. Power Switch |
| 3. Motor                  | 6. Control      |

#### 4.1 Secure Incoming Wires

1. Obtain (self sticking) white plastic Wire Clips provided by NABCO.
2. Adhere each Wire Clip to sides of Header. Insert wiring (as deemed necessary).
  - a. 120 VAC Power wires must be routed separate from other wiring, adhere those Wire Clips inside the Header, near the top to prevent pinching.

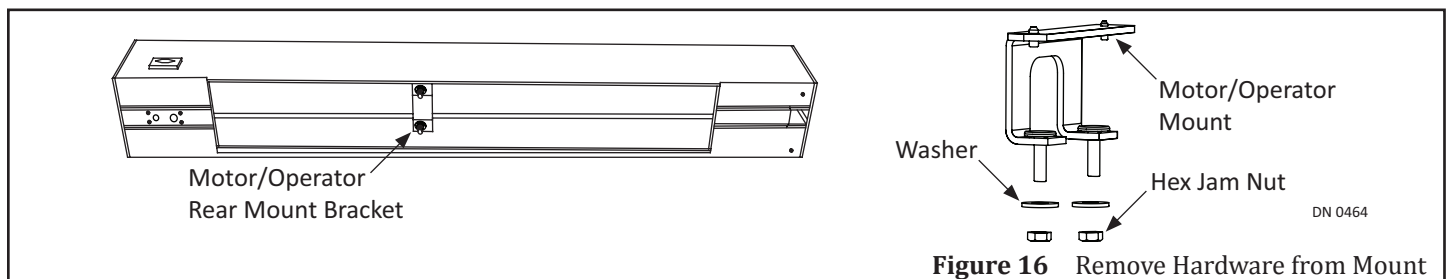


**Figure 15** Adhere White Plastic Wire Clip and Route Wires

*Note: If 120 VAC Power wires must be installed from Hinge Side of Header, ensure that wires are securely clipped, to prevent pinching of the wires during the Motor/Operator installation process.*

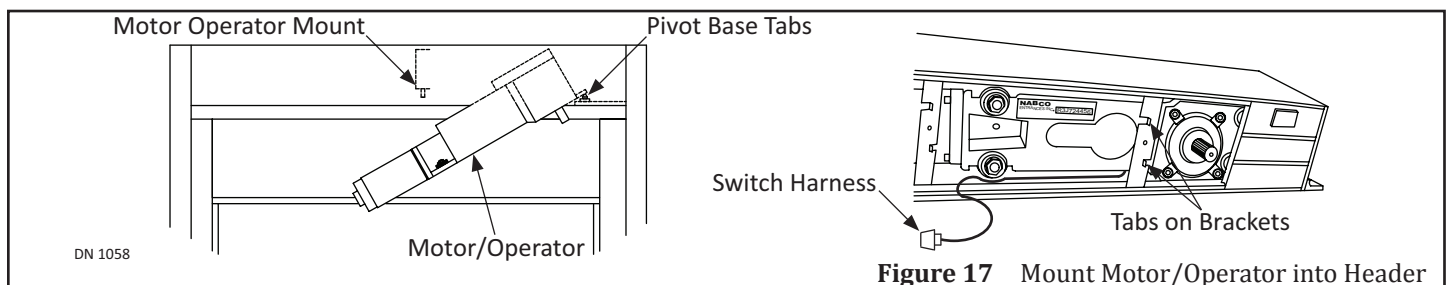
#### 4.2 Install Motor/Operator into Header

1. Go to (inside) top of Header. Locate the Rear Mount Bracket.
2. With a 9/16 inch Deep Well Socket and Ratchet, remove (2) 3/8-16 Hex Jam Nuts and (2) Washers from (2) studs that extend downward from the Rear Mount Bracket. Set aside.
3. Hold the Front end of Motor/Operator at an upward angle to slide Front Mount onto (2) Pivot Base Tabs located inside of Header.



**Figure 16** Remove Hardware from Mount

4. Lift the rear of the Motor Operator up onto (2) studs extending downward.
  - a. Ensure the Switch Harness is tucked between the back wall of Header and above the Mounting Bracket.
5. Secure the Motor/Operator with (2) 3/8-16 inch Hex Jam Nuts and (2) 7/16 x 1 inch Washers.
  - a. It is important not to pinch any wiring during the Motor/Operator installation.



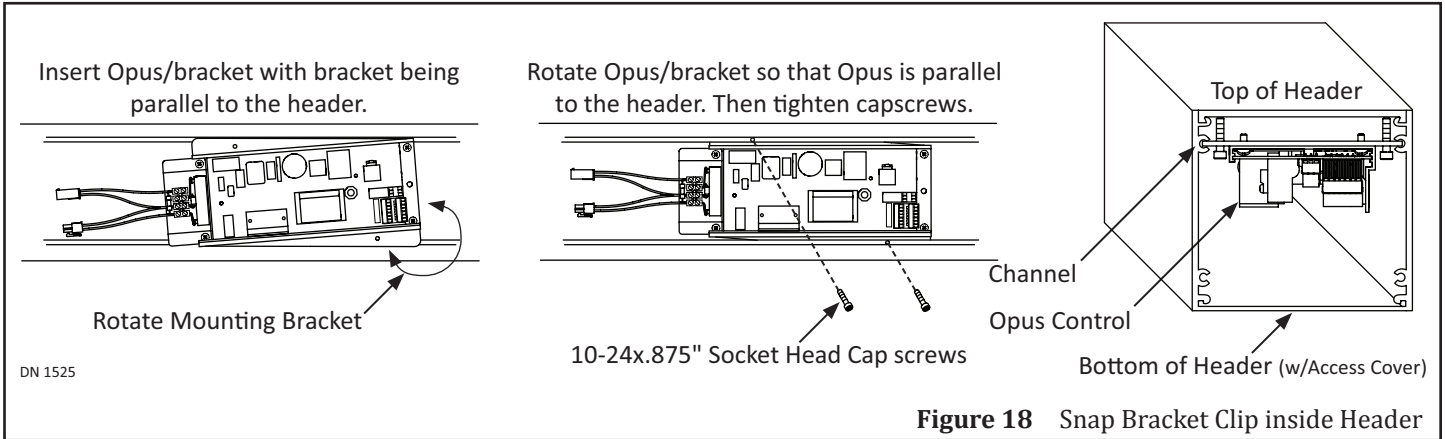
**Figure 17** Mount Motor/Operator into Header

#### 4.3 Install the Control

*Note: It may be necessary to mount a Soft Starter Capacitor on the Operator prior to installing the Analog Control. For detailed information, please refer to the "Analog Control Wiring and Adjustment Manual; P/N 15-10745".*

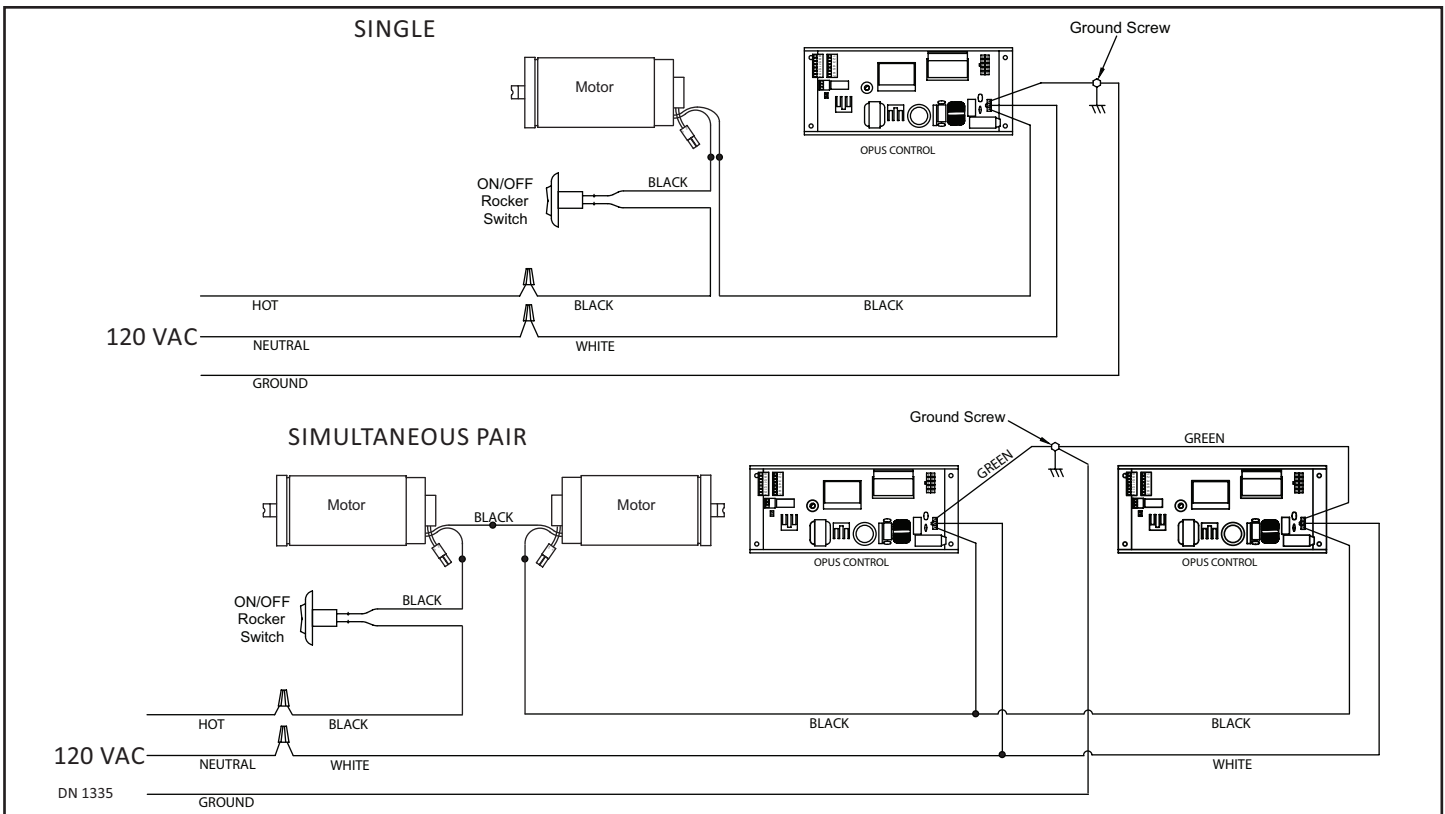
1. Obtain the Opus Control assembly. Locate where the Opus Control needs to be installed within the Header.
2. Insert the Opus Control with the Mounting Bracket at a 90 degree angle (Control will approximately be at a 4 degree angle).
3. Rotate the Opus Control until each side of the Mounting Bracket slides into each Channel located at the top; inside Header.
4. Secure the Mounting Bracket to the Header by tightening (2) 10-24x.875 inch Socket Head Cap screws, until the tip butts against the inside wall of the Header.





**Figure 18** Snap Bracket Clip inside Header

**SECTION 5: 120 VAC GENERAL WIRING**



**WARNING**

Shut the installation site, branch Circuit Breaker OFF. Failure to do so may result in serious personal or fatal injury. When uncertain whether power supply is disconnected, always verify using a voltmeter.

**WARNING**

All high voltage electrical connections must be made by licensed electricians according to National and Local electrical codes/regulations.

**CAUTION**

Permanent wiring shall be employed as required by local codes.

**CAUTION**

Keep all Incoming 120 VAC wiring separate from low voltage wiring within Header. 120 VAC Power wires must be routed (separate from other wiring) located near the top of inside Header.

**CAUTION**

Ensure that the Grounding of the Electric Power Supply is installed/connected in a proper way (especially the PE Cable from the Building Side).

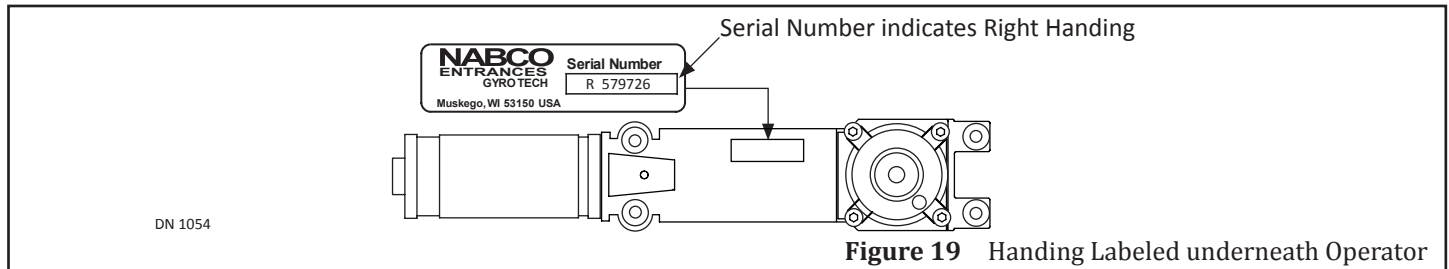
**Attention:** Insert all Incoming 120 VAC Power wires into the pre drilled Electric Service Access Hole located at the left or right side of Header End Cap.

*Note:* It is recommended for the Installer to house all Incoming 120 VAC wires within an Electrical Conduit.

**SECTION 6: HANDING**

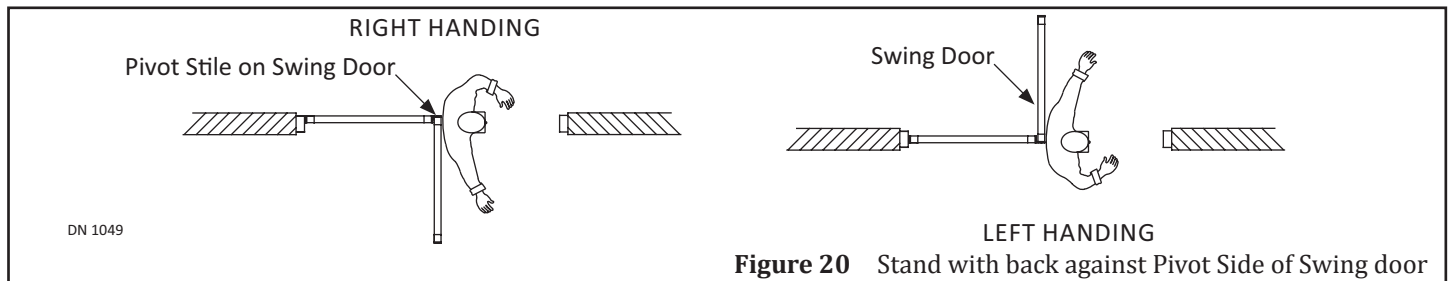
**6.1 How to Determine Handing**

- ▶ Locate the Serial Number underneath the Operator. The Letter (L) or (R) located in front of the Serial Number indicates the Handing.



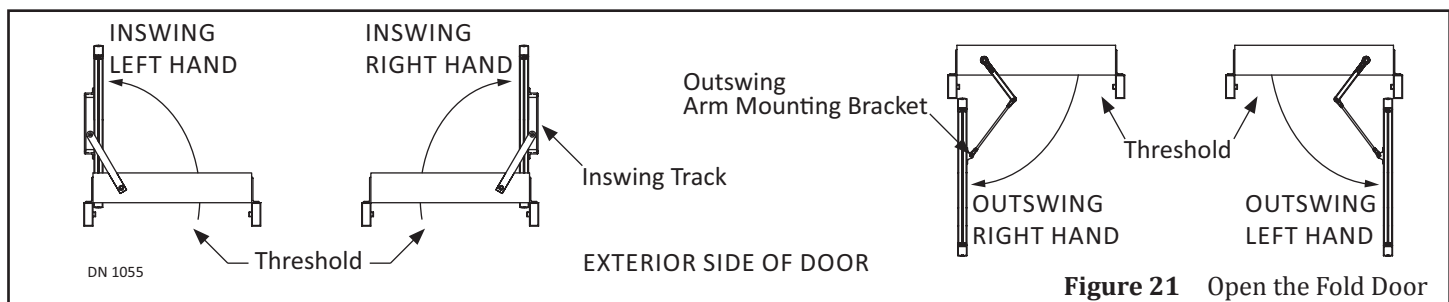
**Figure 19** Handing Labeled underneath Operator

- ▶ Stand underneath the Header and open the Swing door. Butt your back against the Pivot side. Swing out your (right or left) arm in the direction the Swing door opened. If you swing out your Right Arm the Swing Door is Right Handed. If you swing out your Left arm the Swing Door is Left Handed.



**Figure 20** Stand with back against Pivot Side of Swing door

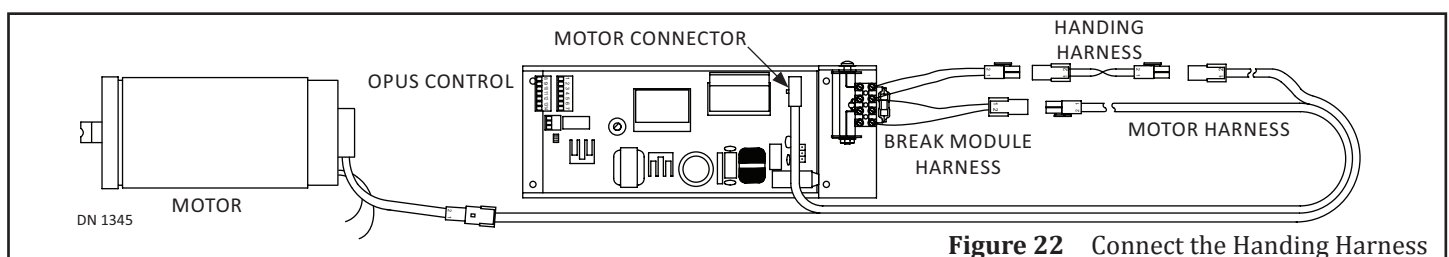
- ▶ If the Swing Arm does not swing underneath the Threshold to open, it is an Inswing Unit.
- ▶ If the Swing Arm swings underneath the Threshold to open, it is an Outswing Unit.



**Figure 21** Open the Fold Door

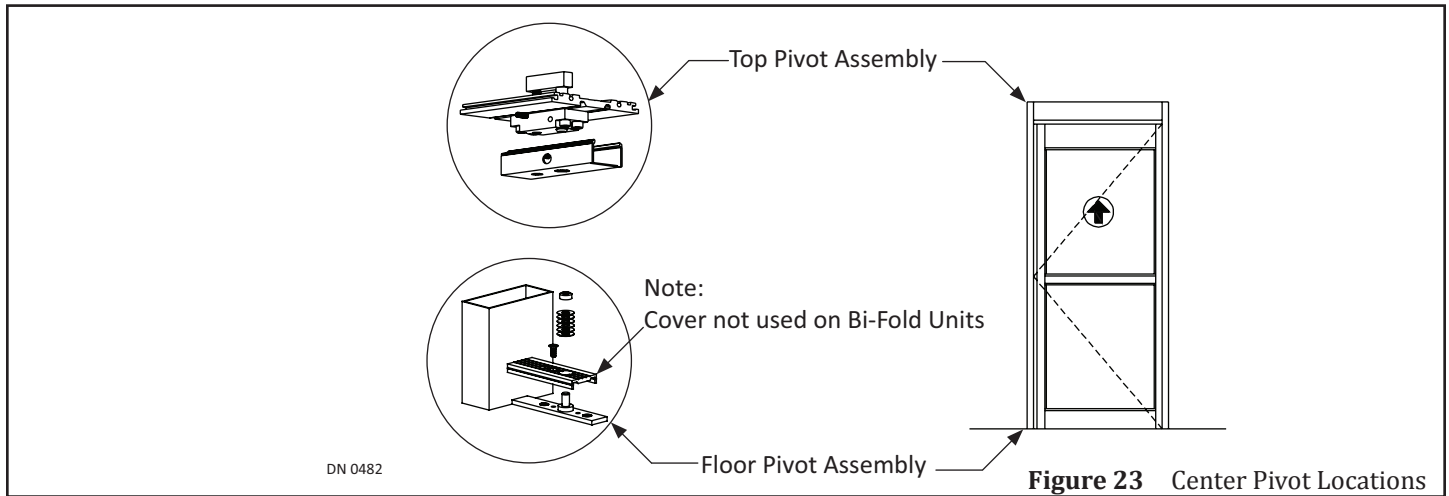
**6.2 Install the Handing Harness (for Right Handed Units only)**

1. Obtain the Handing Harness. Connect the (Break Module Harness) Female Pin to the Male Pin Housing (Handing Harness)
2. Connect the (Break Module Harness) Male Pin Housing to the Female Pin (Handing Harness).

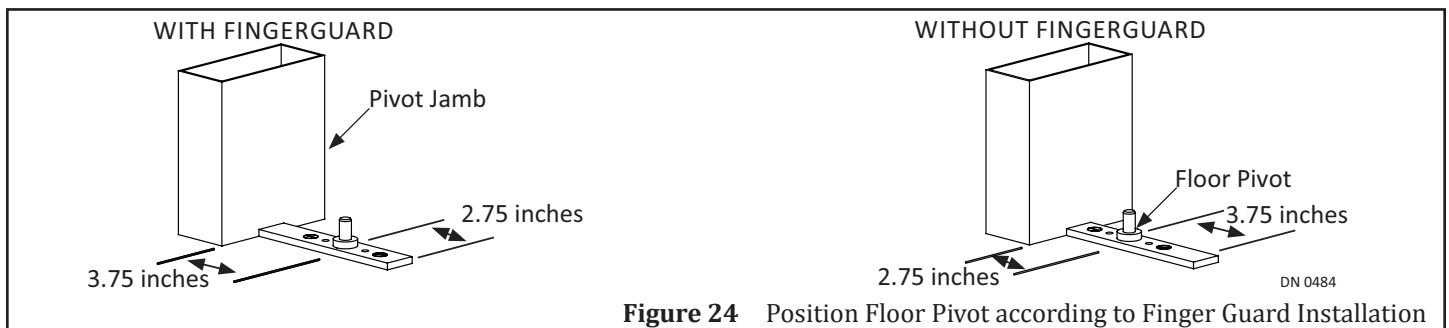


**Figure 22** Connect the Handing Harness

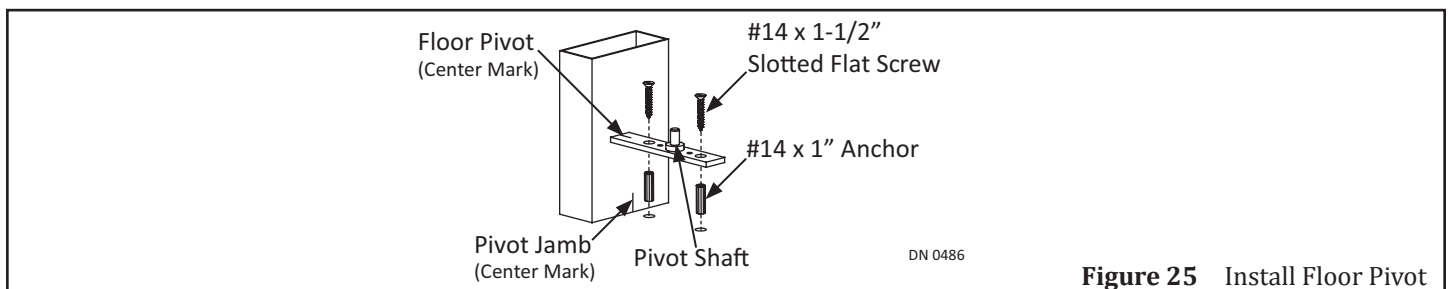
**SECTION 7: INSTALL THE FLOOR PIVOT**



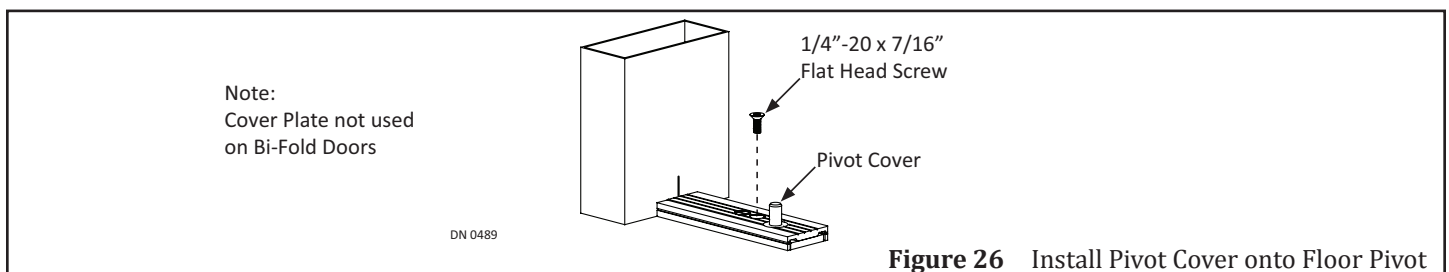
1. Obtain the Floor Pivot Assembly. The Pivot Shaft is not centered on the Floor Pivot. One end is used:
  - ▶ With the Finger Guard; so the Pivot Shaft measures 3.75 inches away from the Pivot Jamb.
  - ▶ Without the Finger Guard; so the Pivot Shaft measures 2.75 inches away from the Pivot Jamb.



2. Measure and mark the center of the Pivot Jamb and the Floor Pivot.
3. Butt the center mark of the Floor Pivot up against the center mark of the Pivot Jamb.
4. Align both Pivot Shafts. Drop a Plumb Line (down the center) from the Top Pivot Shaft to the Floor Pivot Shaft.
5. Use the Floor Pivot as a template to mark and drill (2) holes for #14 x 1 inch Blue anchors provided by NABCO.
6. Insert (2) #14 x 1" Blue anchors into each hole. Secure the Floor Pivot with (2) #14 x 1-1/2 inch Slotted Flat Head Screws.

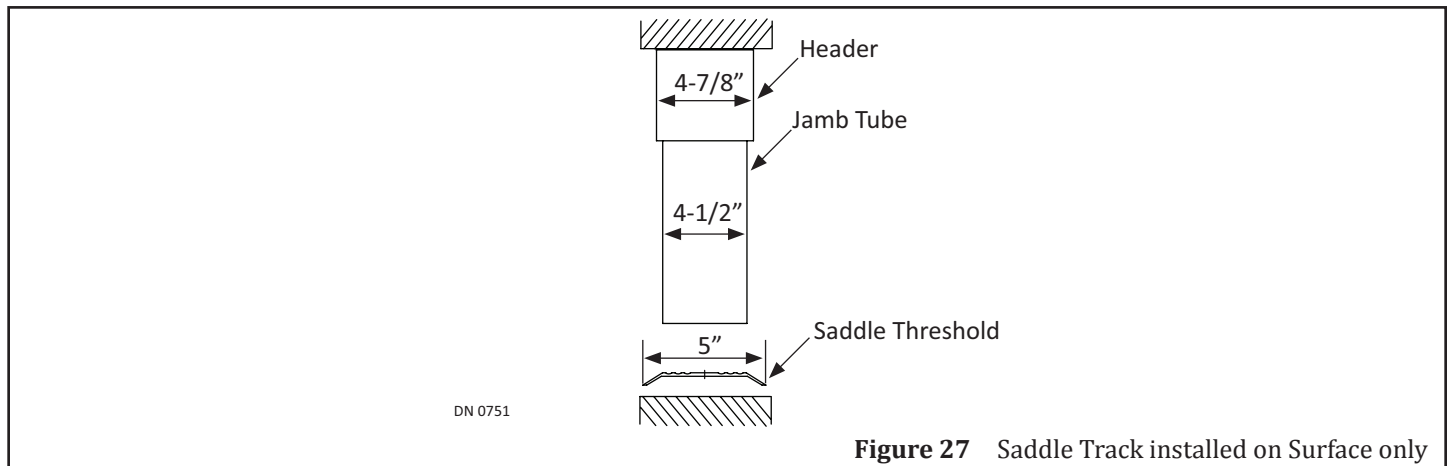


7. Secure the Pivot Cover with (1) 1/2-20 x 7/16 inch Flat Head Machine Screw.



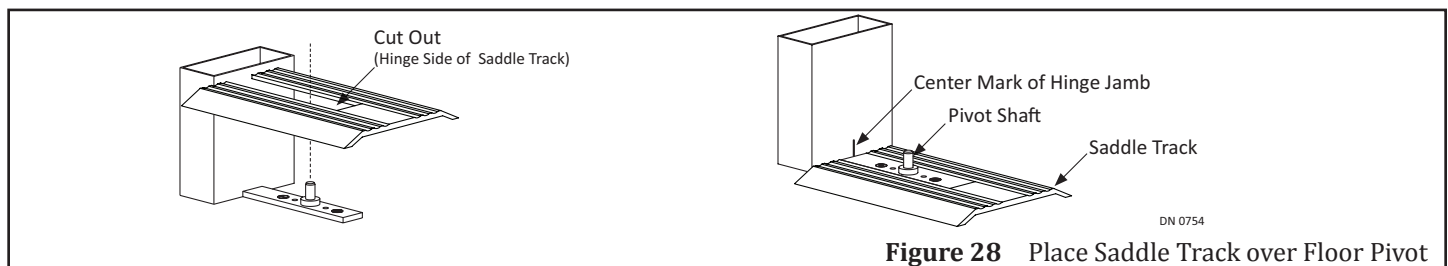
## SECTION 8: LAY DOWN THE SADDLE THRESHOLD OVER THE FLOOR PIVOT

1. Obtain the Saddle Threshold. The Pivot Side of the Saddle Threshold has a cut out for the Pivot Plate.



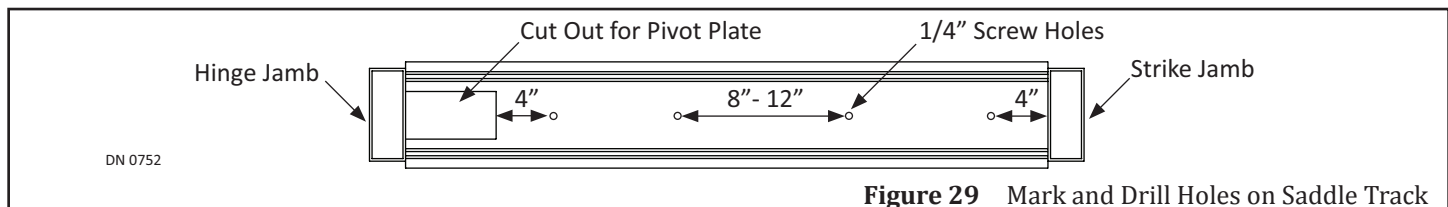
**Figure 27** Saddle Track installed on Surface only

2. Obtain the Saddle Threshold. The Pivot Side of the Saddle Threshold has a cut out for the Pivot Plate. Place the Pivot Side of the Saddle Threshold over the Floor Pivot Assembly. Ensure the Saddle Track is centered to the Strike Jamb and square.



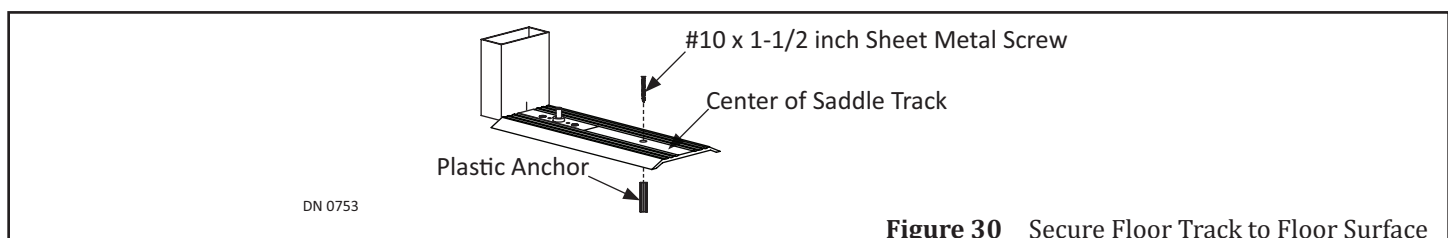
**Figure 28** Place Saddle Track over Floor Pivot

3. Square and center the Saddle Threshold to the Strike Jamb.
4. Obtain #10 x 1-1/2 inch sheet metal screws and anchors (per length of the Saddle Threshold).
5. In the center of the Saddle Threshold, approximately 4 inches from the cutout for the Pivot Plate, mark (1) screw hole.
6. In the center of the Saddle Threshold, approximately 4 inches from the Strike Jamb, mark (1) screw hole.



**Figure 29** Mark and Drill Holes on Saddle Track

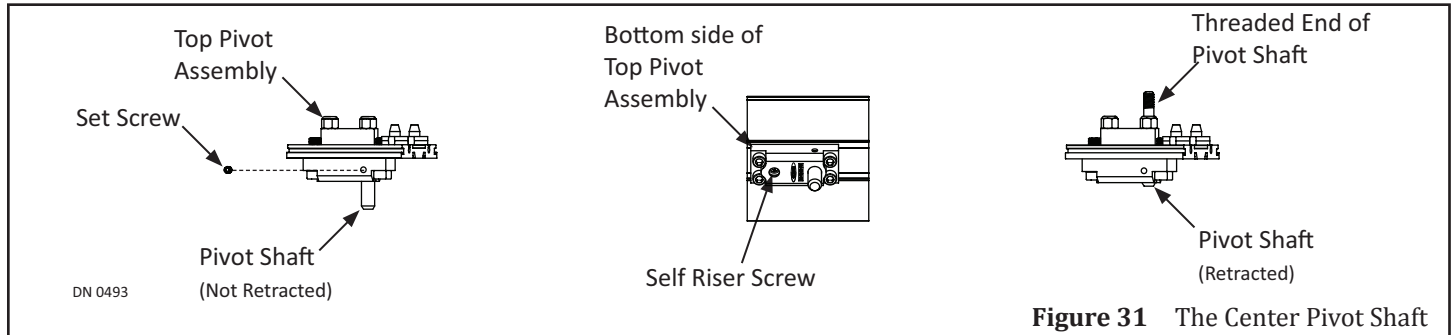
7. Mark remaining screw holes 8 - 12 inches apart and evenly spaced.
8. Drill screw holes into the floor no less than 1-1/2 inch deep for #14 x 1 inch anchors.
9. Remove the Saddle Threshold. Set aside.
10. Insert #14 x 1 inch plastic anchors into the drilled screw holes.
11. Secure the Floor Track with #10 x 1-1/2 inch sheet metal screws (Not provided by NABCO).
  - a. Do not overtighten screws to prevent deforming the Saddle Threshold.



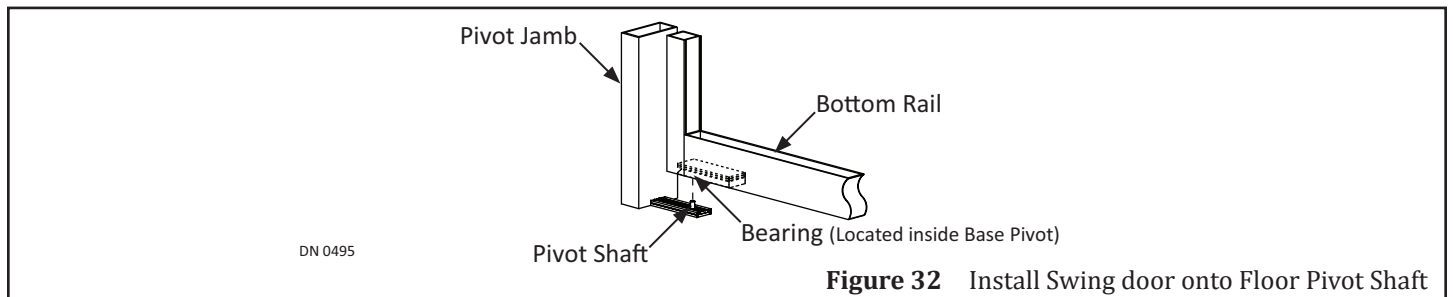
**Figure 30** Secure Floor Track to Floor Surface

**SECTION 9: INSTALL THE SWING DOOR (PROVIDED BY NABCO)*****FOR UNITS NOT PROVIDED BY NABCO SKIP TO SECTION 11***

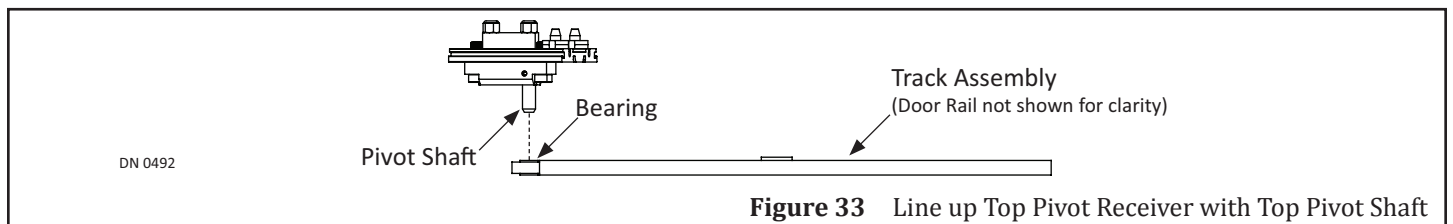
1. Go to the Pivot side of Header. Loosen the Set Screw located directly above the Pivot Shaft.
2. Go to the Self Riser screw located underneath the top Pivot. Turn the Self Riser Screw counter-clockwise to retract the Center Pivot Shaft.

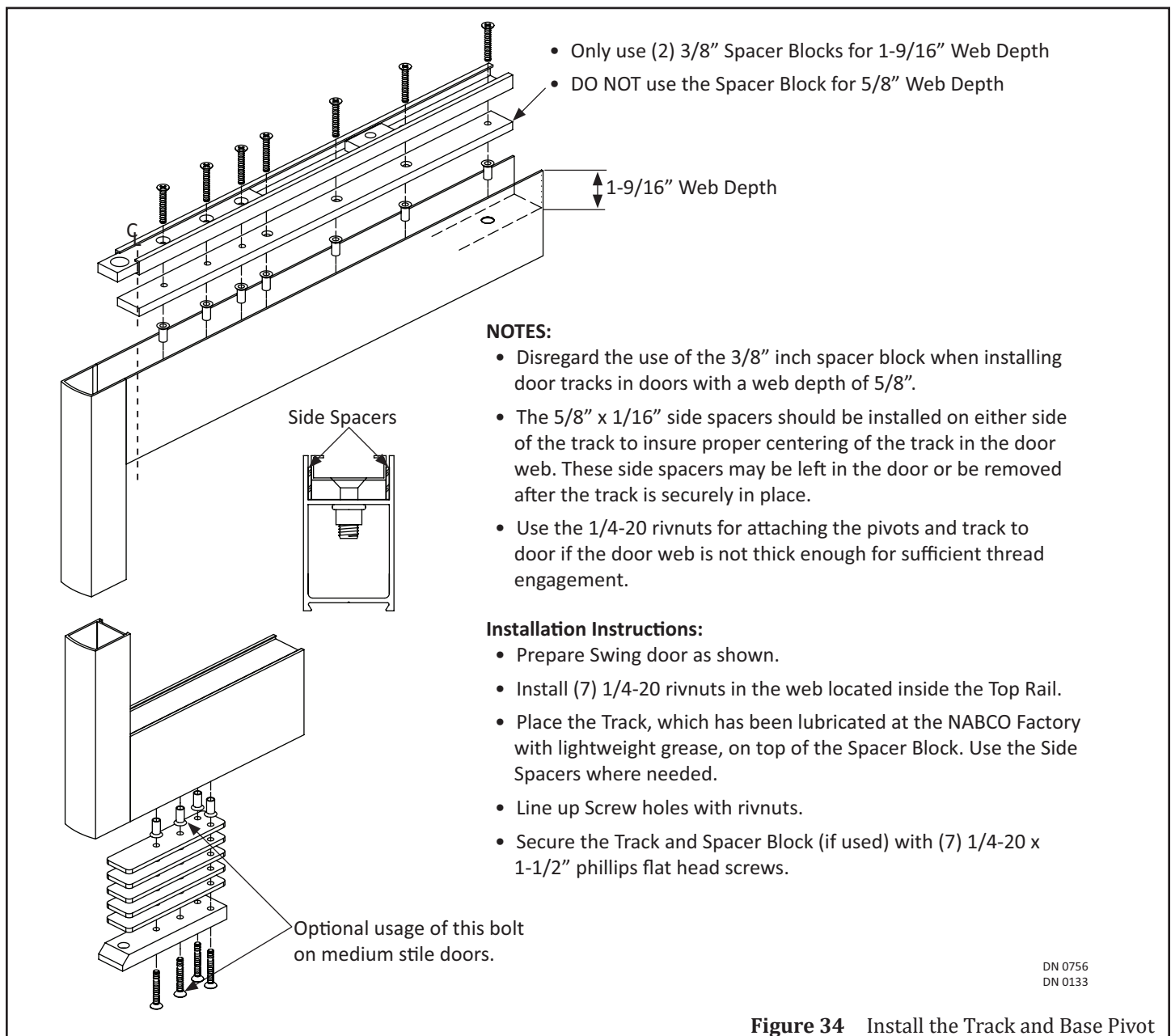


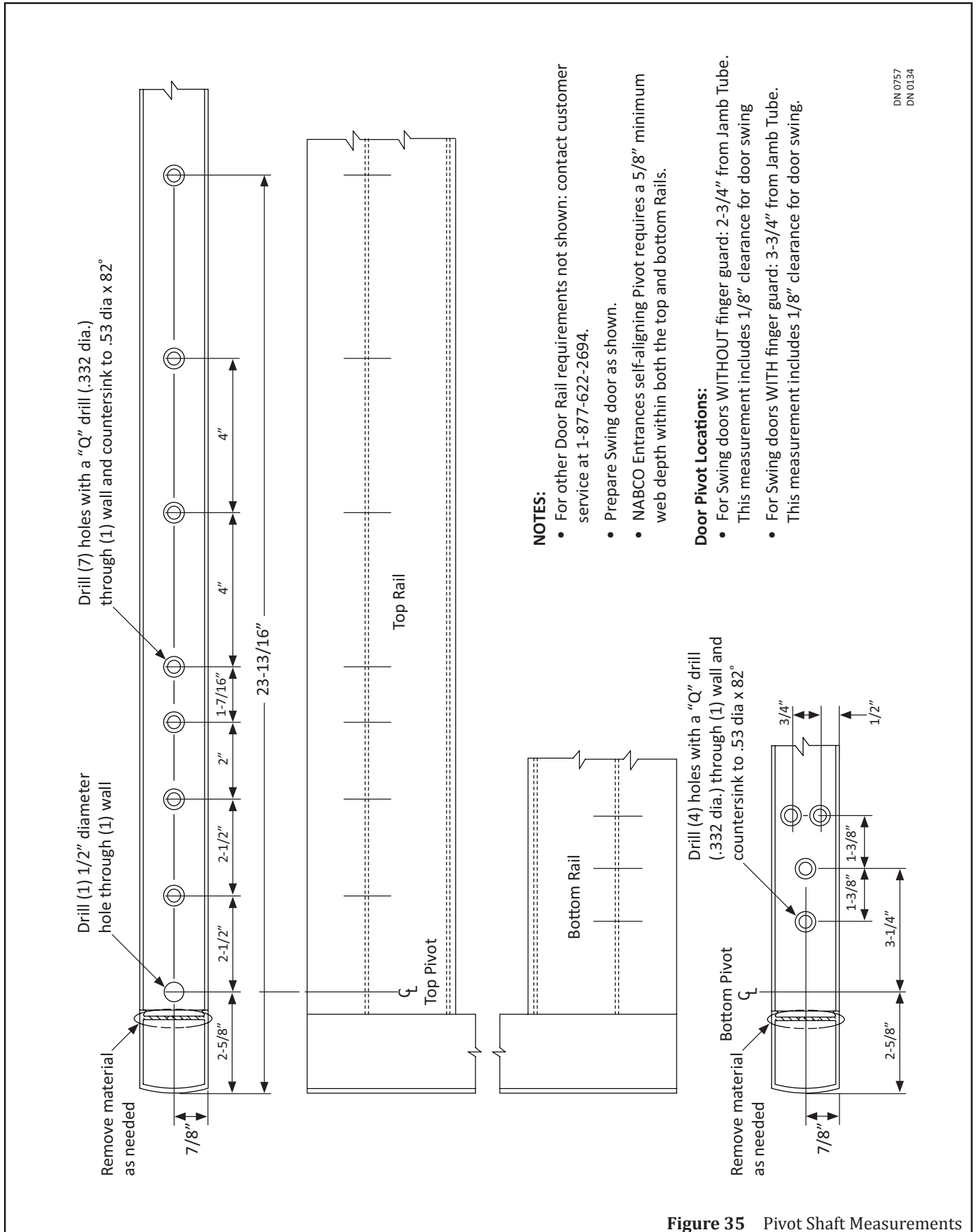
3. Go to the bottom Pivot Assembly. Insert the Ball Bearing onto the Floor Pivot Shaft.



4. Go to the Top Rail. Locate the Track Assembly.
5. With a flat head screwdriver, turn the Self Riser Screw clockwise until the Riser Bar is all the way down into the Bearing.
  - a. Tighten the Riser Bar tight to the base Pivot Plate to ensure the Pivot Shaft is fully engaged inside the Bushing.



**SECTION 10: INSTALL THE SWING DOOR (NOT PROVIDED BY NABCO)****Figure 34** Install the Track and Base Pivot



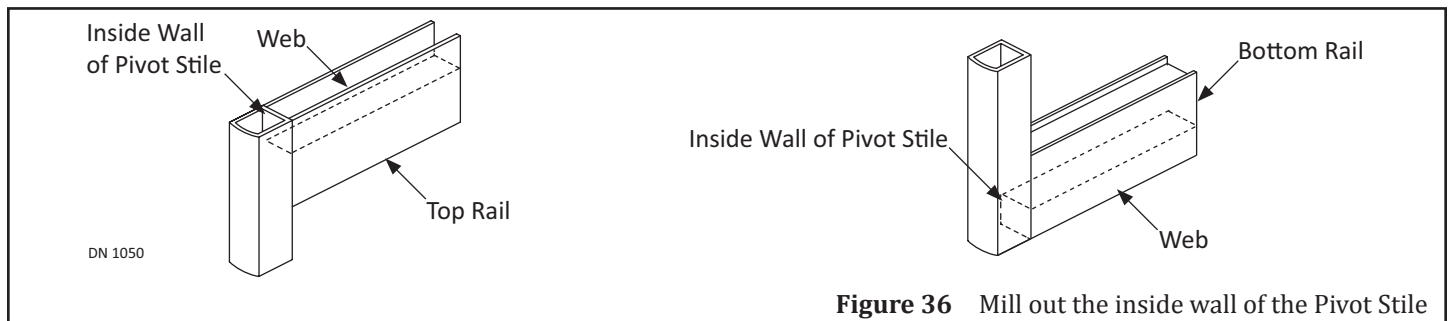
- NOTES:**
- For other Door Rail requirements not shown: contact customer service at 1-877-622-2694.
  - Prepare Swing door as shown.
  - NABCO Entrances self-aligning Pivot requires a 5/8" minimum web depth within both the top and bottom Rails.
- Door Pivot Locations:**
- For Swing doors **WITHOUT** finger guard: 2-3/4" from Jamb Tube. This measurement includes 1/8" clearance for door swing
  - For Swing doors **WITH** finger guard: 3-3/4" from Jamb Tube. This measurement includes 1/8" clearance for door swing.

DN 0757  
DN 0134

**Figure 35** Pivot Shaft Measurements

## 10.1 Prep the Door Rail

The inside wall of the Pivot Stile may butt up against the Door Rail (at the very top). If the Track needs to extend past the Door Rail, the inside wall will need to be milled out to match the width and depth of the Web. This may need to be done to the top Door Rail and/or the bottom Door Rail.

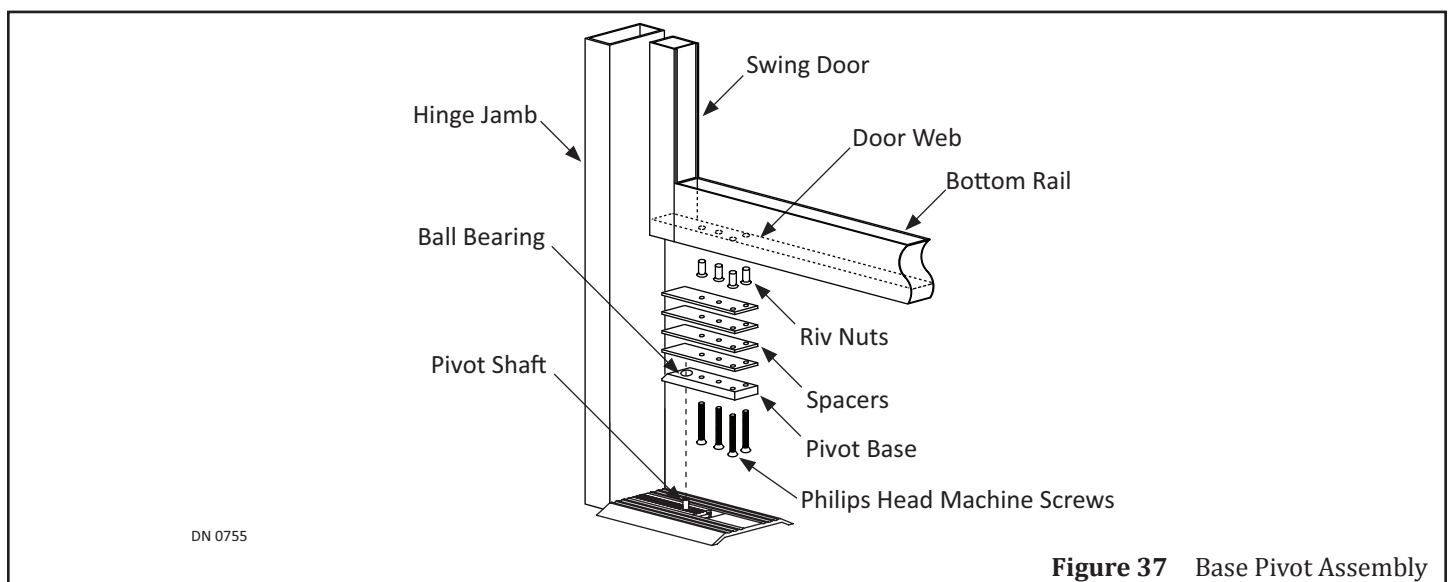


**Figure 36** Mill out the inside wall of the Pivot Stile

## 10.2 Install the Base Pivot into the Bottom Door Rail

*Note: Please refer to Figure 36 for detailed Base Pivot installation measurements.*

- Lay the Swing door onto a flat surface that is sturdy enough to keep the door stable, and high enough to see while drilling.
- Go to the Bottom Rail on the Pivot side of Swing Door. Measure to find the center inside the Web. Mark a horizontal line all the way across the full width of the Web face.
- From the outer edge of the Pivot Stile measure:
  - ▶ With the Finger Guard; 3-5/8 inches.
  - ▶ Without the Finger Guard; 2-5/8 inches.
- Mark a vertical line across the horizontal line onto the Web face. This is the center of the Bearing.
- From the center of the Bearing mark, measure another 3-1/4 inches. Mark a vertical line across the horizontal line onto the Web face. This is the center of the second .322 diameter anchor hole.
- Obtain (1) Spacer. Center the Spacer inside the Web. Align the second screw hole to the second anchor hole marked onto the Web face.
- Use the Spacer as a template to mark the remaining (3) anchor holes. Ensure the Spacer is aligned and centered. Drill (4) .322 anchor holes.
- Countersink the (4) anchor holes to .53 diameter x 82 degrees.
- Insert (4) 1/4-20 tapped Rivnuts into the (4) .322 anchor holes.
- Obtain the Base Pivot assembly. Place (1-4) Spacers on the bottom side of the Pivot Base.
  - a. The Gel filled Bearing is located on the top side of the Pivot Base.
- Insert the Pivot Base assembly up into the Web. Add/subtract spacers until the Base Pivot is flush to the outside edge of the Door Rail. Secure the Pivot Base to the Web with (4) 1/4 - 20 x 2 inch Phillips Head Machine Screws.

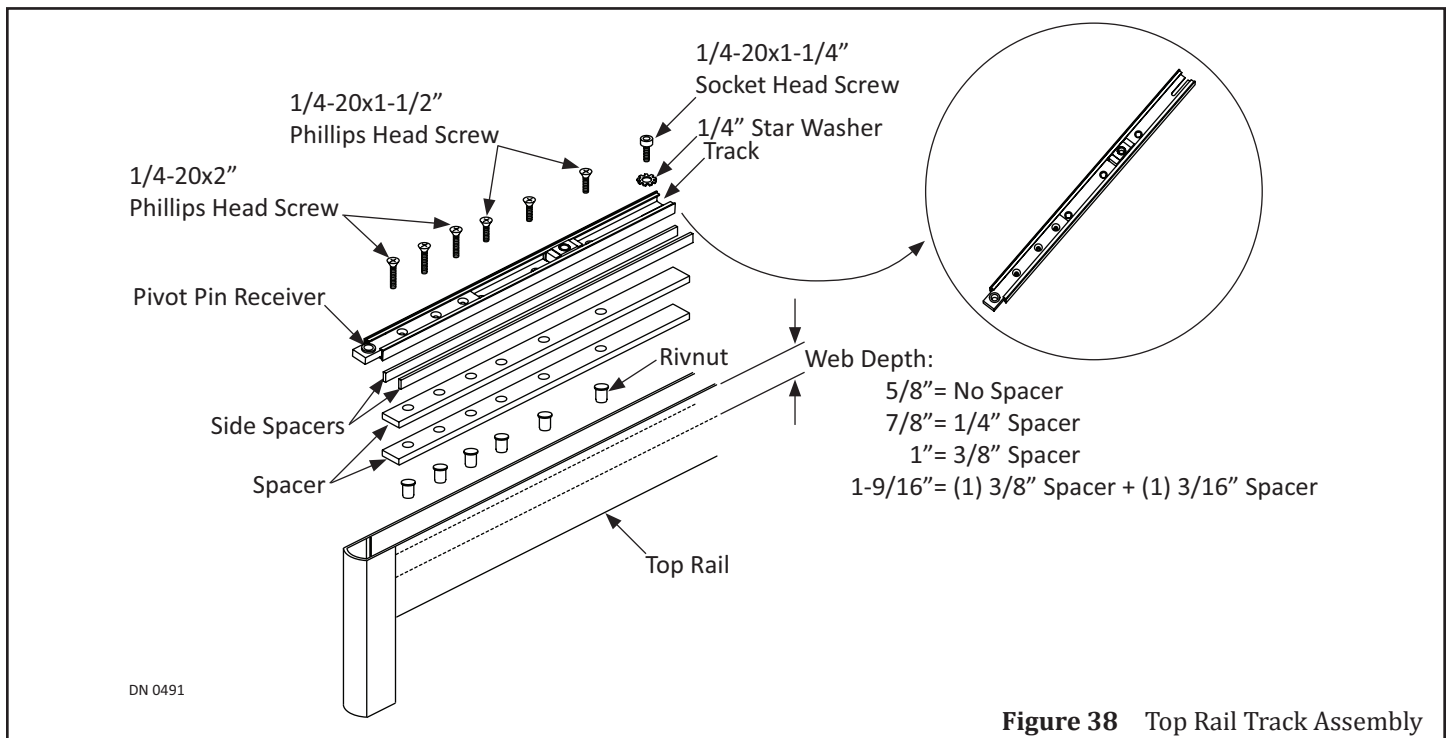


**Figure 37** Base Pivot Assembly



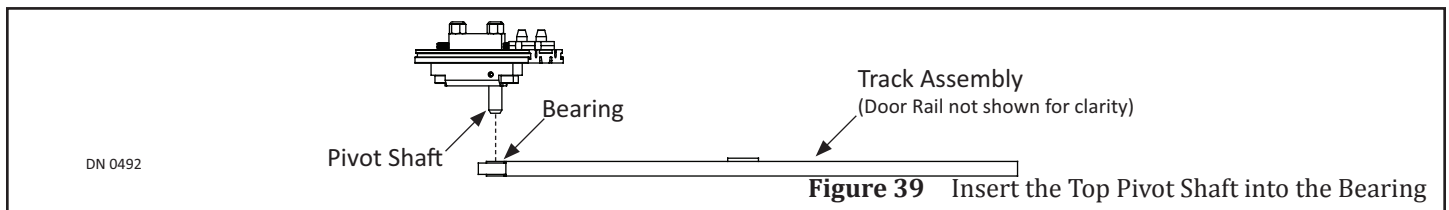
### 10.3 Partially Install the Track into the Top Door Rail

1. Lay the Swing door on a flat surface that is sturdy enough to keep the door stable, and high enough to see while drilling.
2. Go to the Top Rail on the Pivot side of Swing Door. Measure to find the center inside the Web. Mark a horizontal line all the way across the full width of the Web face.
3. From the outer edge of the Pivot Stile measure 23-13/16 inches. Mark a vertical line across the horizontal line onto the Web Face. This is the center of (1) .322 anchor hole.
4. Drill (1) .322 anchor hole.
5. Countersink the anchor hole to .53 diameter x 82 degrees. It is recommended to drill tap threads for anchors in a steel or aluminum structure.
6. Insert (1) 1/4-20 tapped Rivnut into the .322 anchor hole.
7. Obtain the Track Assembly. Place (1) Spacer Block inside the Web according to the Web Depth:
  - ▶ 5/8 inch deep: No Spacer Block is required
  - ▶ 7/8 inch deep: Insert 1/4 inch Spacer Block
  - ▶ 1 inch deep: Insert 3/8 inch Spacer Block
  - ▶ 1-9/16 inch deep: Insert (2) 3/8 inch Spacer Blocks
8. Place (1) Track on top of the Spacer Block (or the Web if a Spacer Block is not used).
  - a. Ensure the Pivot Pin Receiver is on the Pivot Side of the Web.
9. Place (2) 5/8 " x 1/16" Side Spacers on either side of the Track. Side Spacers are used to ensure proper centering of Track.



**Figure 38** Top Rail Track Assembly

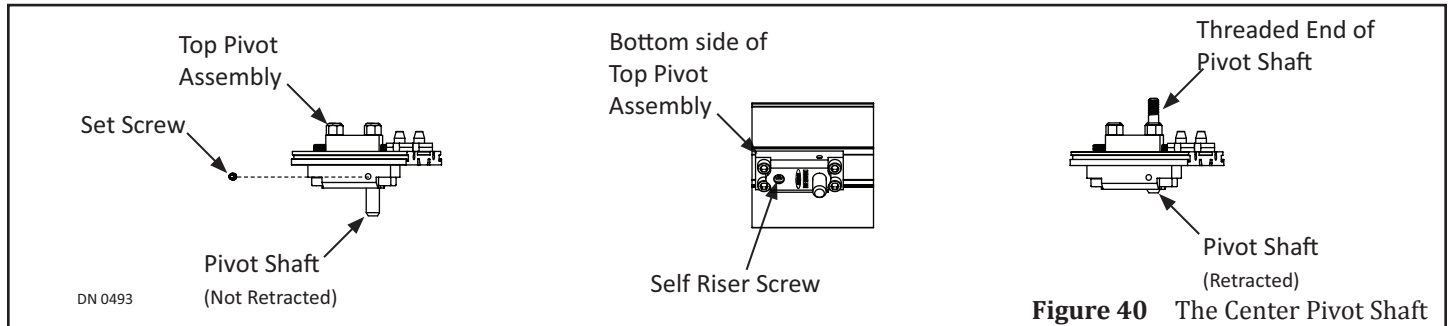
10. From the outer edge of the Pivot Stile measure:
  - ▶ With the Finger Guard; 3-5/8 inches.
  - ▶ Without the Finger Guard; 2-5/8 inches
11. Slide the Track towards the Pivot Stile or away from the Pivot Stile until the Bearing is centered to that measurement.
12. Locate the Slot at the end of the Track. Locate the Pre-drilled screw hole.
13. Secure the Track to the Web with (1) 1/4 inch Star Washer and (1) 1/4-20x1-1/4 inch Socket Head screw. Tighten but do not overtighten. The Socket Head screw may need to be loosened one more time.



**Figure 39** Insert the Top Pivot Shaft into the Bearing

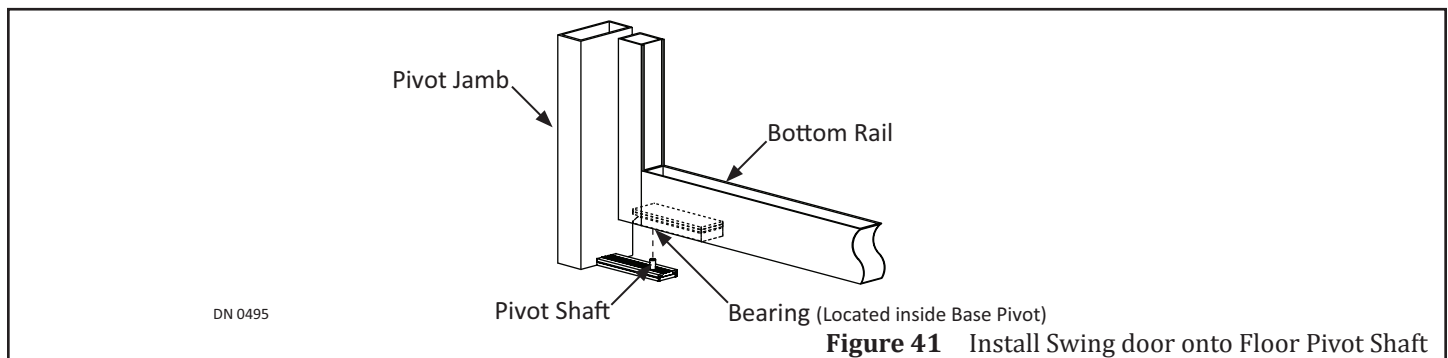
## 10.4 Temporarily Install the Swing Door

1. Go to the Pivot side of Header. Locate the Pivot Assembly.
2. Loosen the Set Screw located directly above the Pivot Shaft.
3. Go to the Self Riser screw located underneath the Pivot Assembly.
4. Turn the Self Riser Screw counter-clockwise to retract the Pivot Shaft.



**Figure 40** The Center Pivot Shaft

5. Go to the bottom Door Rail. Slide the Bearing onto the Pivot Shaft.



**Figure 41** Install Swing door onto Floor Pivot Shaft

6. Go to the top Door Rail. Turn the Self Riser Screw clockwise to insert the Pivot Shaft into the Bearing.
7. With a flat head screwdriver, turn the Self Riser Screw clockwise until the Pivot Shaft is inserted all the way down into the Bearing.
8. Slide the Track Assembly back and forth until the Swing door is properly aligned.
  - a. It is recommended to use a Level.
9. Tighten the Set Screw, do not overtighten. The Set Screw may have to be loosened one more time.

### 10.4.1 Align the Swing Door

1. Fully open the Swing door.
2. Go to the Track Assembly located inside the Top Rail.
3. Loosen (1) 1/4-20x1-1/4 inch Socket Head Screw.
4. Slide the Track Assembly back and forth until the Swing door is properly aligned.
  - a. It is recommended to use a Level.
5. Tighten the Socket Head Screw but do not tighten all the way down.
  - a. The Socket Head Cap Screw may need to be loosened one more time.

### 10.4.2 Adjust the Swing Door\Height

1. Measure for proper clearance:
  - ▶ Top of Swing door must be: 1/8 inch to 1/16 inch from Header.
  - ▶ Bottom of Swing door must be: 3/16 inch to 1/16 inch from Floor (or threshold if it is installed).
2. Remove the Swing door.
3. Slide (1-6) Spacer Shims onto the Pivot Shaft to adjust the Swing door for proper clearance.
4. Slide (1) Self Aligner Cap on top of the (1-6) Spacer Shims.
5. Reinstall the Swing door.
6. Check the alignment.

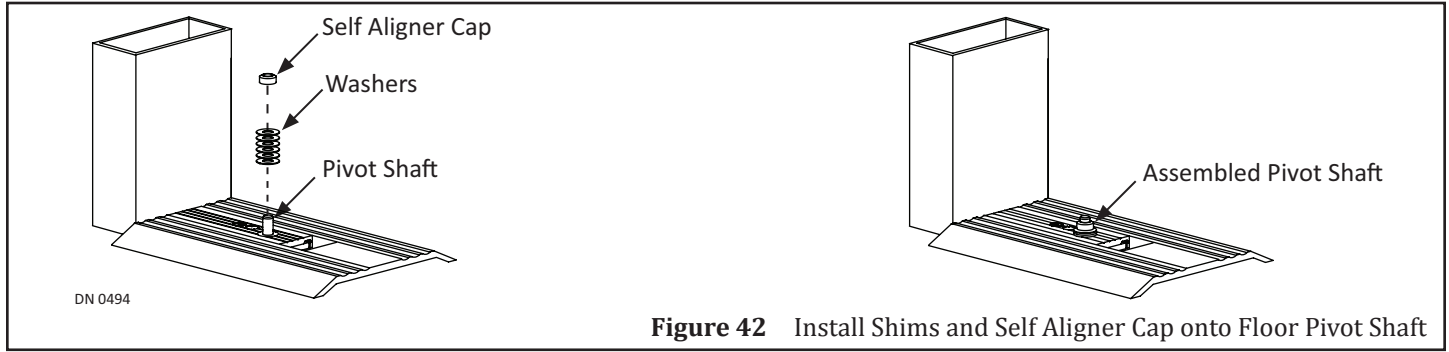


Figure 42 Install Shims and Self Aligner Cap onto Floor Pivot Shaft

**SECTION 11: PERMANENTLY INSTALL THE SADDLE THRESHOLD**

1. Fully open the Swing door.
2. Obtain (5) or more 1/4 x 1-1/4 inch Flathead Phillips Tapcon screws.
  - a. The number of screws and anchors depends upon the length of the Saddle Threshold.
3. In the center of the Saddle Threshold, approximately 4 inches from the cutout for the Pivot Plate, mark (1) screw hole.
4. In the center of the Saddle Threshold, approximately 4 inches from the Strike Jamb, mark (1) screw hole.

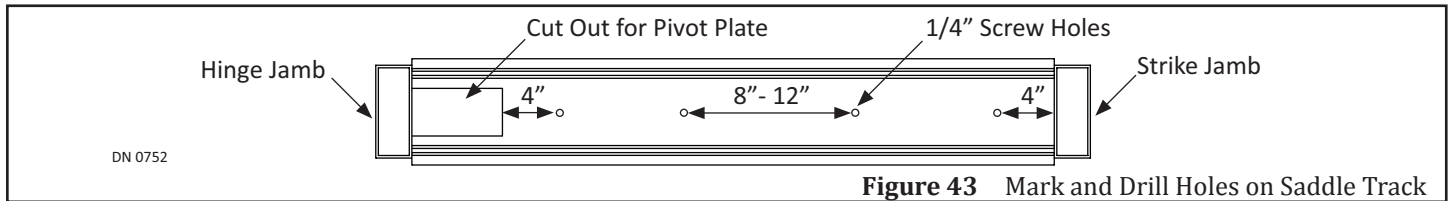


Figure 43 Mark and Drill Holes on Saddle Track

5. Mark remaining screw holes 8 - 12 inches apart and evenly spaced.
6. Secure the Threshold with fasteners not provided by NABCO.
  - a. Do not overtighten screws to prevent deforming the Saddle Threshold.

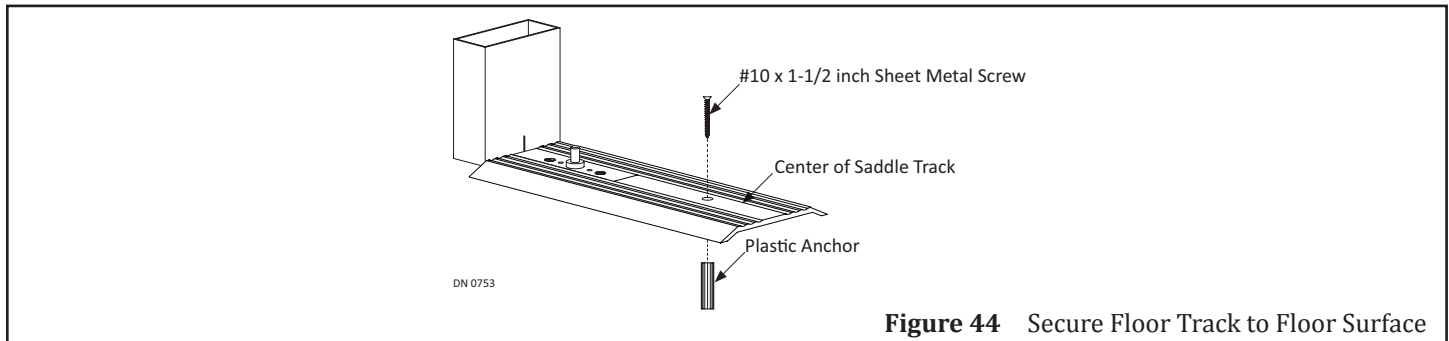


Figure 44 Secure Floor Track to Floor Surface

**SECTION 12: INSTALL THE SWING ARM**

**12.1 Prep the Swing Arm**

1. Obtain the Swing Arm. With an 5/16 inch Allen Wrench, remove the Pivot Screw and (3) washers. Set aside.
2. Remove the Set Screw. Loosen the Shoulder Bolt with an 3/16 inch Allen Wrench. Set aside.

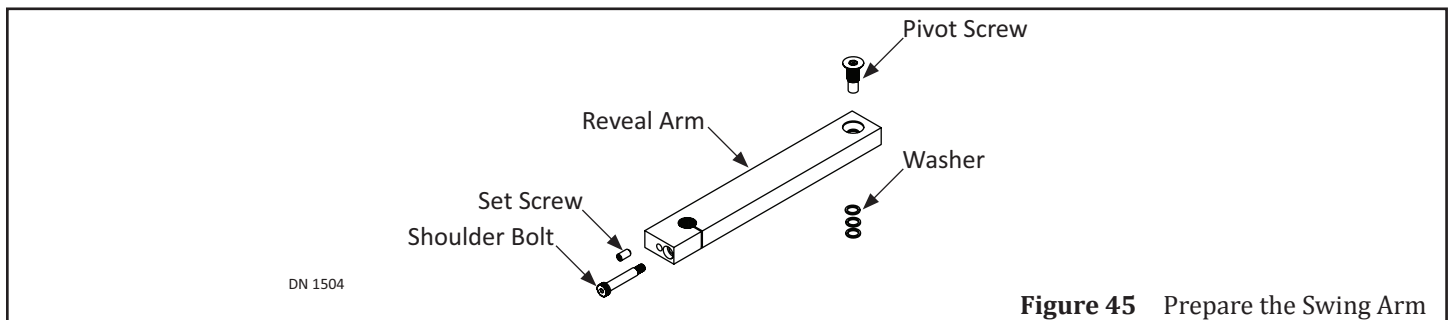


Figure 45 Prepare the Swing Arm

## 12.2 Set Pre-Load

### CAUTION

Power must be turned OFF during the Swing Arm installation.

### DANGER

Ensure the Motor/Operator is plugged into the Controller.

### DANGER

Do not allow the Pin or 1/8 inch Allen Wrench to drop out of the Lovejoy Coupling Access hole at any time during installation. The Swing Arm will spring back to its original location and can result in personal injury or damage.

Table 1 Pre-Load

Full Energy	Low Energy	Inswing Panic Breakout (Only)
18 degrees to 144 degrees	18 degrees or no greater than	144 degrees only (do not hit backstop)
Not to exceed 15 to 30 pounds of Pressure	Not to exceed 15 pounds of Pressure	Not to exceed 50 pounds of Pressure
18 degrees equals (1) Tooth on the Spline		

- Obtain (1) Pin or 1/8 inch Allen Wrench.
- Ensure the Spring on the Operator is in the Unwound (0 degree) position.
  - The Motor/Operator is shipped in the Unwound (0 degree) position.
- Go underneath the Header. Locate the Operator Spindle.
- Slide the Swing Arm onto the Spindle.
- Wind the Operator by rotating the Swing Arm Clockwise for Left handing; Counterclockwise for Right Handing; according to the degrees listed within Table 1:
  - ▶ Full Energy: Spring on Operator must be wound up approximately 126 - 144 degrees (7 - 8 Teeth on Spline).
  - ▶ Inswing Panic Breakout: Spring on Operator must be wound up approximately 144 degrees (8 Teeth on Spline).
    - With a firm grip, rotate the Swing Arm approximately 72 degrees (4 Teeth on Spline).
    - While holding the Swing Arm in that position, insert (1) Pin or 1/8 inch Allen Wrench into the Lovejoy Coupling Access Hole.
      - If necessary, ease the Swing Arm back until the Pin or 1/8 inch Allen Wrench engages the Lovejoy Coupling.
    - Remove the Swing Arm from the Operator Spindle.
      - The Pin or 1/8 inch Allen Wrench will keep the Spring from unwinding.
    - Go to the 0 degree position again, slide the Swing Arm back onto the Operator Spindle. With a firm grip, rotate the Swing Arm an additional 54 - 72 degrees. The Spring on the Operator should be wound approximately 126 - 144 degrees.
      - Remove the Swing Arm.
  - Low Energy: Spring on Operator must be wound up approximately 18 degrees (1 Tooth on Spline).
    - With a firm grip, rotate the Swing Arm approximately 18 degrees (1 Tooth on Spline).
    - While holding the Swing Arm in that position, insert (1) Pin or 1/8 inch Allen Wrench into the Lovejoy Coupling Access Hole.
      - If necessary, ease the Swing Arm back until the Pin or 1/8 inch Allen Wrench engages the Lovejoy Coupling.

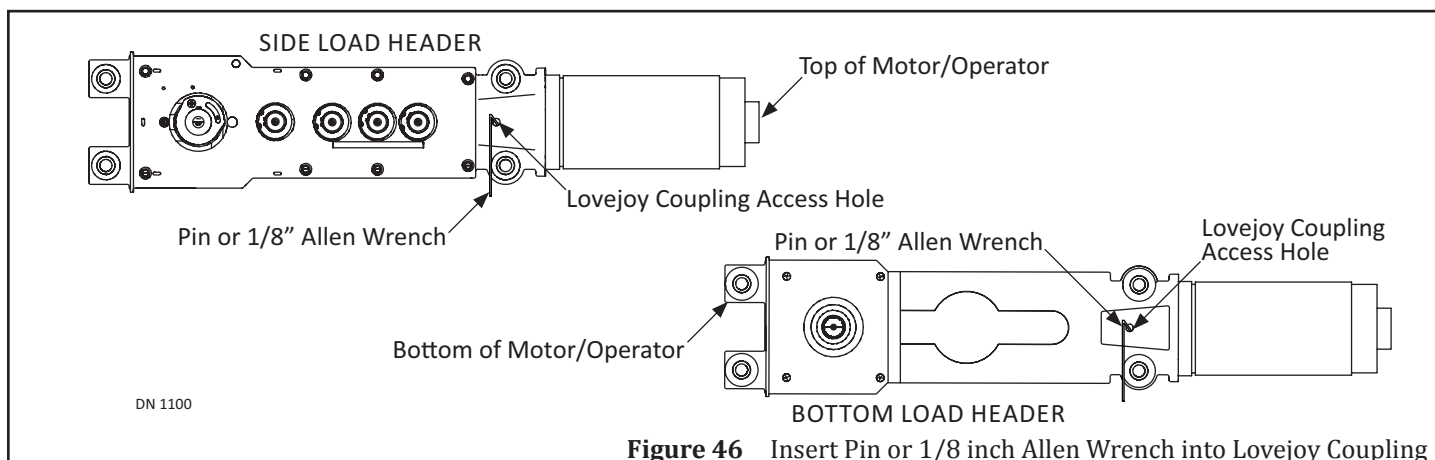
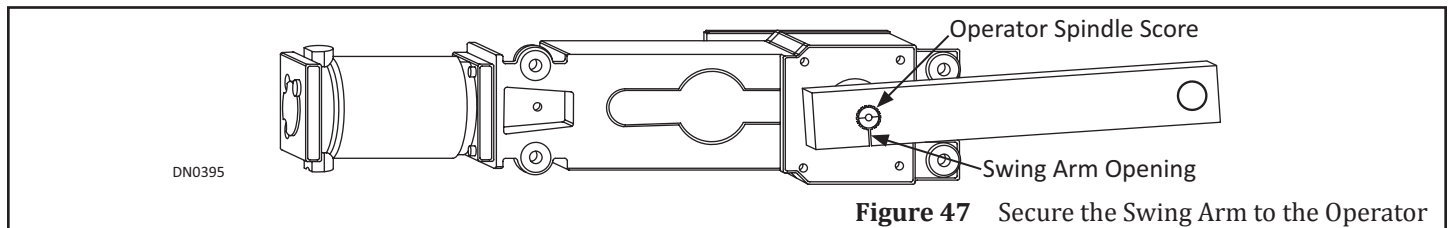


Figure 46 Insert Pin or 1/8 inch Allen Wrench into Lovejoy Coupling

6. Remove the Swing Arm from the Operator Spindle.
7. Carefully remove the Pin or 1/8 inch Allen Wrench from the Operator.

### 12.3 Secure the Swing Arm to the Operator

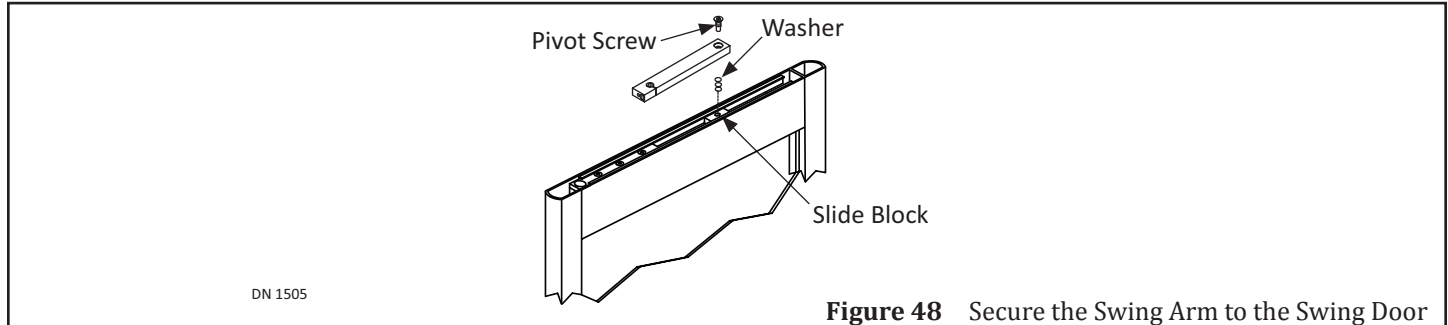
1. Fully close the Swing door. Go to the Output Spindle located at the bottom of the Operator.
  - a. A Score has been etched onto the bottom of Output Spindle.
2. Line up the Opening located on the bottom of the Swing Arm so it is perpendicular to the Spindle Score. Slide the Swing Arm onto the Spindle. Please see Figure 48.
3. Tighten the Shoulder Bolt. Reinsert Set Screw. Tighten.



**Figure 47** Secure the Swing Arm to the Operator

### 12.4 Secure the Swing Arm to the Swing Door

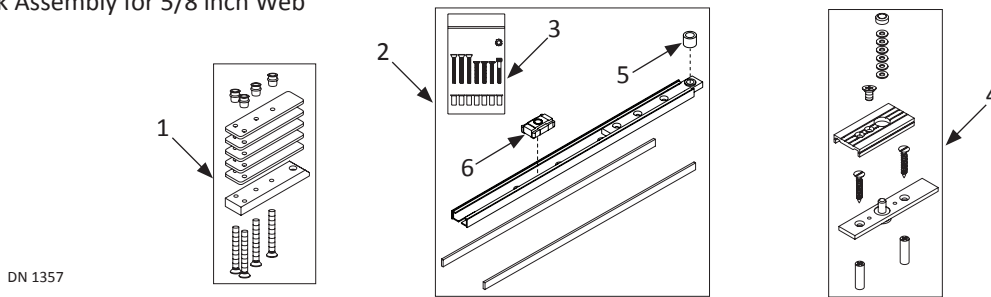
1. Open the Swing Door.
2. insert (1) Pin or 1/8 inch Allen Wrench into the Lovejoy Coupling Access Hole.
  - a. If necessary, ease the Swing Arm back until the Pin or 1/8 inch Allen Wrench engages the Lovejoy Coupling
3. Rotate the Swing Arm to align the Pivot Screw hole (located on free end of Swing Arm) to the Top Slide Block.
4. Check to see how many Washers will be necessary to install between the Swing Arm and the Swing door.
  - ▶ 3 for 3/16 inch Clearance Door 2 for 1/8 inch Clearance Door 1 for 1/16 inch Clearance Door
5. Secure the Swing Arm and Washers to the Slide Block with the Pivot Screw. Tighten.
6. Carefully remove the Pin or 1/8 inch Allen Wrench from the Operator.



**Figure 48** Secure the Swing Arm to the Swing Door

### SERVICE PARTS: BAG P/N A-00565

OHC Track Assembly for 5/8 inch Web

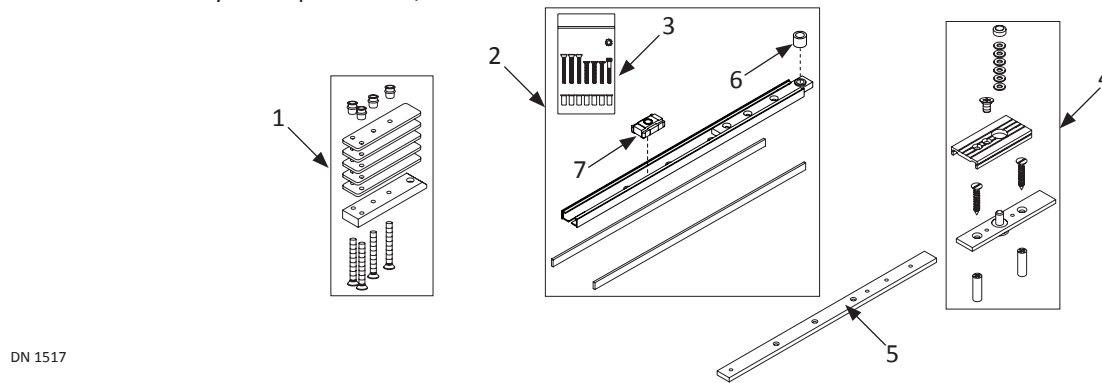


#### OHC Track for 5/8 inch Web: A-00565

Item	Part	QTY	Description	Used To
1	A-00500	1	BTTM PIVOT ASSY, DOOR PORTION, SWING DR	Open/Close the Swing Door
2	A-00459	1	PIVOT BLOCK,O.H.C.,TRACK W/STOP	Seat Swing Arm within the Top Web
3	A-00450	1	PARTS BAG,O.H.C. TRACK,SCREW	Secure Track Assembly inside the Top Web
4	A-00417	1	FLOOR PIVOT ASSY, PIN & COVER	Open/Close the Swing Door
5	V-00115	1	BEARING, 1/2 x 3/4 x 5/8" WIDE	Seat Pivot Pin
6	A-00456	1	SLIDE BLOCK,ASSY	Slide Swing Arm inside Track to Open/Close Door

### SERVICE PARTS: BAG P/N 21-3561

OHC Track Assembly with Spacer for 7/8 inch Web

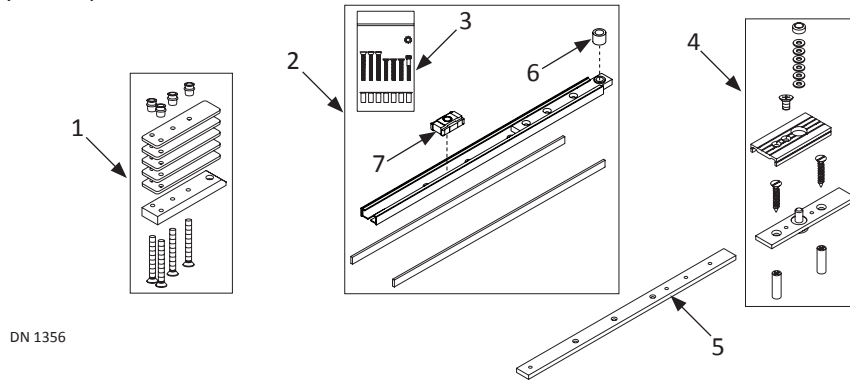


#### OHC Track for 7/8 inch Web: 21-3561

Item	Part	QTY	Description	Used To
1	A-00500	1	BTTM PIVOT ASSY, DOOR PORTION, SWING DR	Open/Close the Swing Door
2	A-00459	1	PIVOT BLOCK,O.H.C.,TRACK W/STOP	Seat Swing Arm within the Top Web
3	A-00450	1	PARTS BAG,O.H.C. TRACK,SCREW	Secure Track Assembly inside the Top Web
4	A-00417	1	FLOOR PIVOT ASSY, PIN & COVER	Open/Close the Swing Door
5	A-00948	1	SPACER BLOCK	Adjust height of Track within Top Rail (1/4 inch)
6	V-00115	1	BEARING, 1/2 x 3/4 x 5/8" WIDE	Seat Pivot Pin
7	A-00456	1	SLIDE BLOCK,ASSY	Slide Swing Arm inside Track to Open/Close Door

**SERVICE PARTS: BAG P/N 21-0928**

OHC Track Assembly with Spacer for 1 inch Web

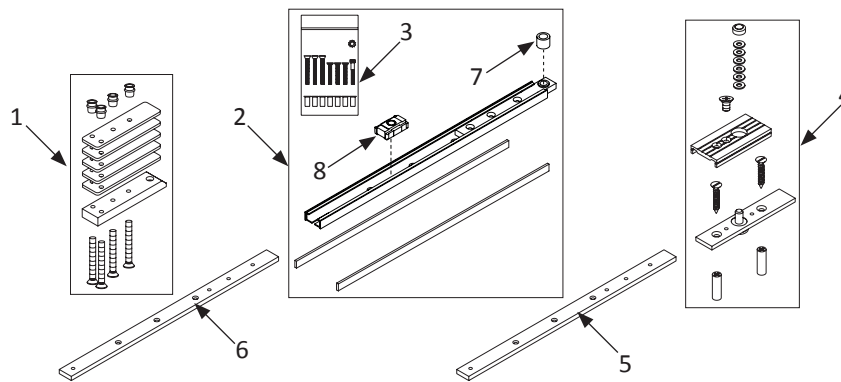


**OHC Track for 1 inch Web: 21-0928**

Item	Part	QTY	Description	Used To
1	A-00500	1	BTTM PIVOT ASSY, DOOR PORTION, SWING DR	Open/Close the Swing Door
2	A-00459	1	PIVOT BLOCK,O.H.C.,TRACK W/STOP	Seat Swing Arm within the Top Web
3	A-00450	1	PARTS BAG,O.H.C. TRACK,SCREW	Secure Track Assembly inside the Top Web
4	A-00417	1	FLOOR PIVOT ASSY, PIN & COVER	Open/Close the Swing Door
5	M-01342	1	BLOCK - SPACER 3/8	Adjust height of Track within Top Rail
6	V-00115	1	BEARING, 1/2 x 3/4 x 5/8" WIDE	Seat Pivot Pin
7	A-00456	1	SLIDE BLOCK,ASSY	Slide Swing Arm inside Track to Open/Close Door

**SERVICE PARTS: BAG P/N 21-5106**

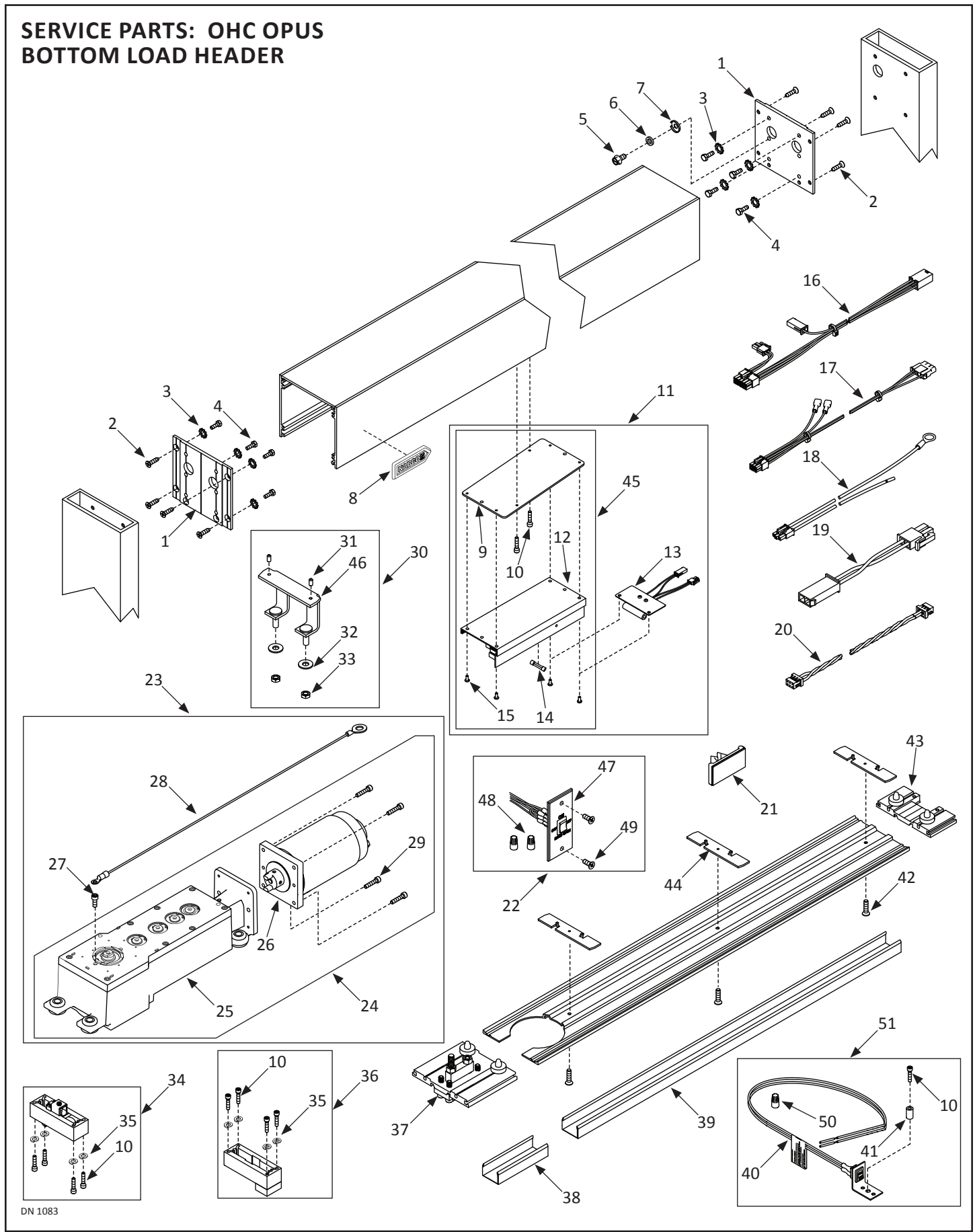
OHC Track Assembly with Spacer for 1-9/16 inch Web



**OHC Track for 1-9/16 inch Web: 21-5106**

Item	Part	QTY	Description	Used To
1	A-00500	1	BTTM PIVOT ASSY, DOOR PORTION, SWING DR	Open/Close the Swing Door
2	A-00459	1	PIVOT BLOCK,O.H.C.,TRACK W/STOP	Seat Swing Arm within the Top Web
3	A-00450	1	PARTS BAG,O.H.C. TRACK,SCREW	Secure Track Assembly inside the Top Web
4	A-00417	1	FLOOR PIVOT ASSY, PIN & COVER	Open/Close the Swing Door
5	M-01337	1	BLOCK,SPACER,3/16"	Adjust height of Track within Top Rail
6	M-01342	1	BLOCK - SPACER 3/8	Adjust height of Track within Top Rail
7	V-00115	1	BEARING, 1/2 x 3/4 x 5/8" WIDE	Seat Pivot Pin
8	A-00456	1	SLIDE BLOCK,ASSY	Slide Swing Arm inside Track to Open/Close Door

# SERVICE PARTS: OHC OPUS BOTTOM LOAD HEADER



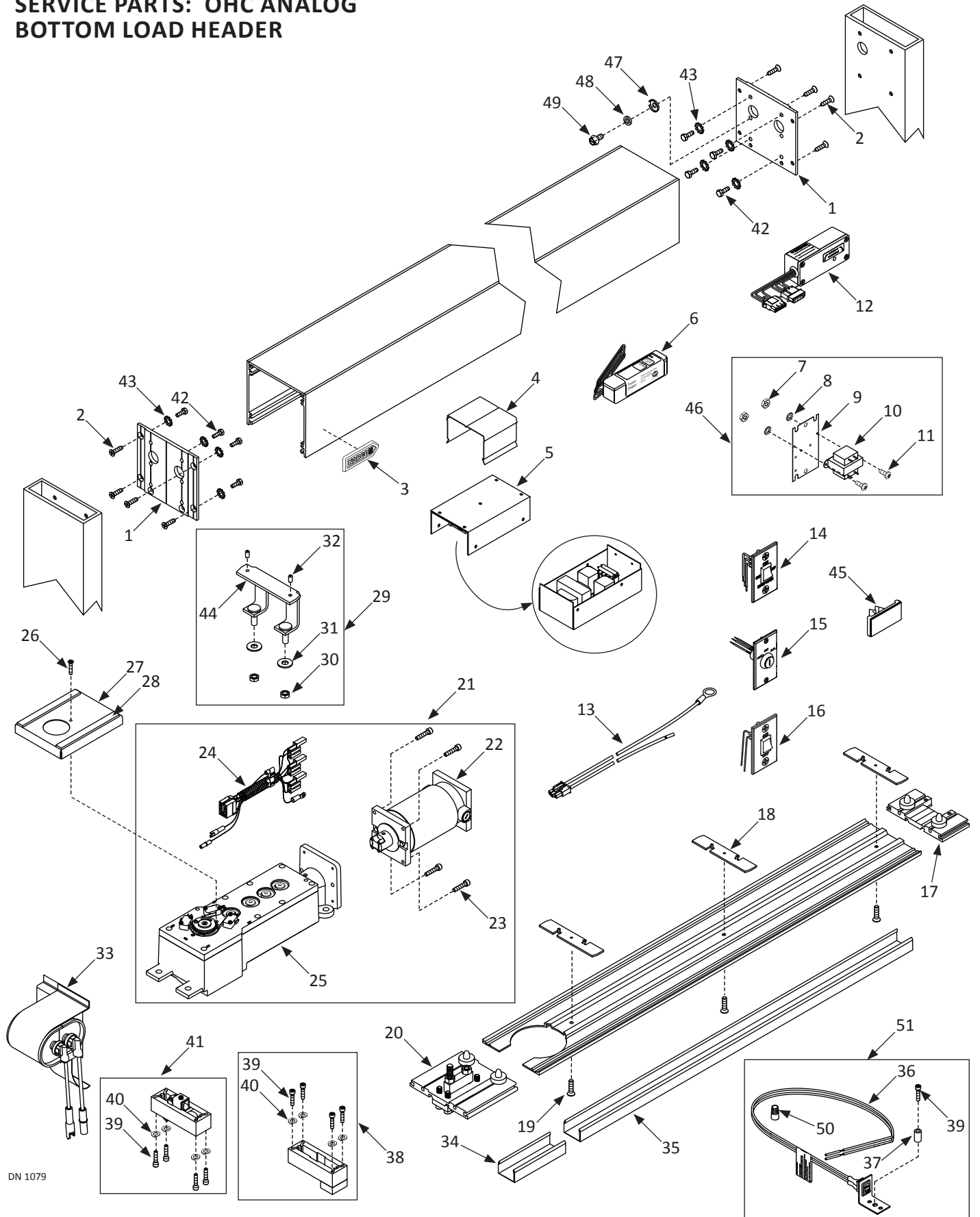
DN 1083



Opus Bottom Load Header			
Item	Part	Finish/Sizes/Notes	Description
1	A-01379	Clear	END CAP,SWING HEADER,BTM LOAD,O.H.C.,204
	A-71379	Dark Bronze	END CAP,SWING HEADER,BTM LOAD,O.H.C.,313
2	T-00061		FHMS,1/4-20x1.000L.,PHIL,TRI-LOBE,ZINC
3	T-00087		WASHER, LOCK, EXT, 1/4 ID, ZINC
4	T-00064		HHCS,1/4-20x0.750L.,ZINC
5	T-00346		HHCS:1/4-20x0.375L:GREEN:WASH HD:SLOT
6	M-00450		SPACER,MTG.END CAP
7	V-00104		WASHER, CUP.312 ID X .88 OD X .040 THICK
8	C-00067		NAMEPLATE,NABCO LOGO
9	M-01735		PLATE,BOTTOM LOAD,OPUS
10	T-00232		SHCS,10-24x0.875L.,ZINC
11	A-01098		CONTROLLER,W/ BRAKE,BOTTOM LOAD,OPUS
12	M-01546		CONTROLLER,OPUS
13	A-01003		MODULE,BRAKE,OPUS
14	V-00288	Used on Brake Module	FUSE,3 AMP,250V,FAST,2AG,AXIAL LEAD
	V-00552	Used on Opus Control	FUSE;5A;GMA;5X20mm
15	T-00420		PHMS,8-32x0.375L,PHIL,SWAGEFORM,ZINC
16	A-01000	Not used on GT710/8710	HARNESS,MOTOR,OPUS
17	A-01002	Retrofit Kit only	HARNESS,ADAPTER,NON-ENCODER,OPUS
18	M-01072		HARNESS,POWER,MAGNUM/OPUS
19	A-01001	Not used on GT710/8710	HARNESS,HANDING,OPUS
20	M-01680	Simultaneous Pair	HARNESS,SIM PAIR,OPUS
21	V-00098		SADDLE, WIRE
22	A-00805		SWITCH,ROCKER,SWINGER,ON/OFF/HOLD OPEN
23	A-01091	RH	"OPER.SWGR,W/ENCOD,ROF;RH;NO CLUTCH;S-LO
	A-01090	LH	"OPER.SWGR,W/ENCOD.ROF;LH;NO CLUTCH;S-LO
24	A-00824	RH	"OPERATOR,SWGR,W/ENCODER, RH CLUTCHLESS"
	A-00823	LH	"OPERATOR,SWGR,W/ENCODER, LH CLUTCHLESS"
25	A-01053	RH	"OPER. SWINGER,W/O MTR.,NO CLUTCH,RH;ROF
	A-01052	LH	"OPER. SWINGER,W/O MTR.,NO CLUTCH,LH;ROF
26	V-00090		MOTOR,SHORT FRAME,ENCODER,DUOWEI
27	T-00185		SHCS,10-24x0.500L.,BK.OX.
28	A-00620		GROUND WIRE:SWING OPERATOR:MAGNUM
29	T-00103		"SHCS,10-24x0.875L.,W-LOCK PATCH"
30	A-00501		BRKT.;MOTOR;REAR;BTM.LOAD
31	T-00073		SHSS,1/4-20x0.500L.,KNURL PT.
32	T-00092		WASHER,.438 ID,1.00 OD,.083 THK,ZINC
33	T-00067		NUT,HEX,JAM,3/8-16,ZINC
34	A-00430	Clear	KIT,PANIC LATCH,O.H.C.204
	A-70430	Dark Bronze	KIT,PANIC LATCH,O.H.C.,313
35	T-00231		WASHER, LOCK, SPLIT, #10 ID, ZINC
36	A-00643		DOOR STOP:NON PANIC

Opus Bottom Load Header			
Item	Part	Finish/Sizes/Notes	Description
37	21-1590	Clear/No Finger Guard	OHC TOP PIVOT & BASE ASSY (NO FINGER GUARD)
	21-1591	Dark Bronze/No Finger Guard	OHC TOP PIVOT & BASE ASSY (NO FINGER GUARD)
	A-00560	Clear/Finger Guard	TOP PIVOT/BASE:OHC:204
	A-70560	Dark Bronze/Finger Guard	TOP PIVOT/BASE:OHC:313
38	A-61176	Clear	"FILLER CHANNEL;HINGE STILE;5-15/32,204"
	A-71176	Dark Bronze	"FILLER CHANNEL;HINGE STILE;5-15/32,313"
39	M-60897	Clear	CHANNEL,SNAP IN,204,,EXTRU
	M-70897	Dark Bronze	CHANNEL,SNAP IN,313,EXTRU
40	M-01085		HARNESS, POWER SWITCH - SWINGERS/710
41	V-00283		SPACER,CIRCUIT BOARD,STANDOFF
42	T-00391		"FHMS,10-24x0.750L.,PHIL,ZINC"
43	M-01374	Clear	OHC,SINGLE STRIKE BASE,3-1/4"
	M-71374	Dark Bronze	OHC,SINGLE STRIKE BASE,3-1/4"
44	M-01177		LOCK COVER PLATE - BOTTOM
45	A-01143		CONTROLLER,W/O BRAKE,BOTTOM LOAD,OPUS
46	M-01181		TOP FRAME MOUNT, SUB - ASSY - SWINGER
47	M-01576		SWITCHPLATE,ON/OFF/HOLD OPEN
48	T-00197		NUT,WIRE,RANGE 22-14AWG,GREY
49	T-00031		FHMS,10-32x0.500L.,PHIL,UCUT,T-LOBE,BKZN
50	T-00047		NUT,WIRE,72B,2-18AWG-3-16AWG
51	A-00409		PARTS BAG,ON/OFF,SWINGER,SWITCH

### SERVICE PARTS: OHC ANALOG BOTTOM LOAD HEADER

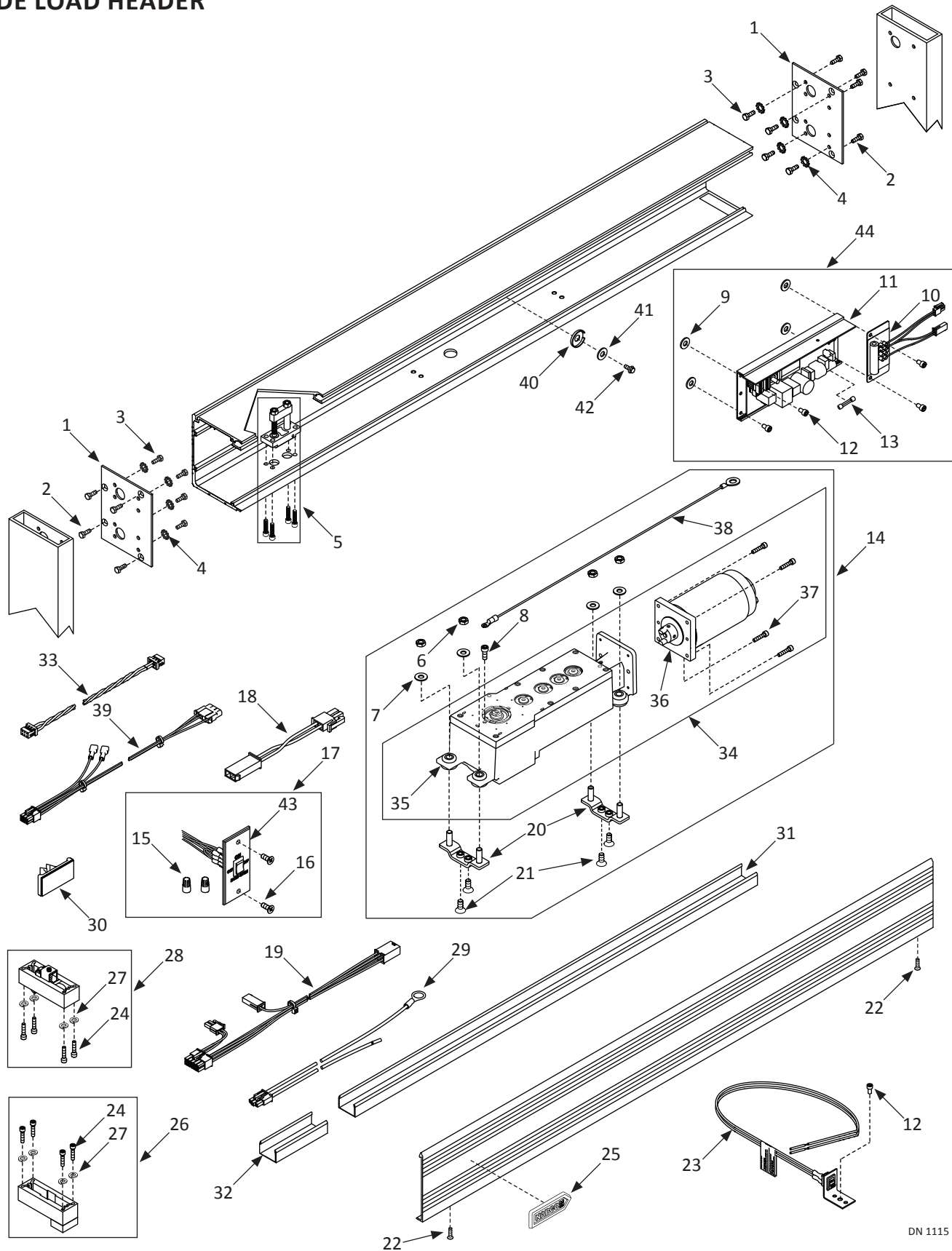


DN 1079

Analog Bottom Load Header			
Item	Part	Finish/Sizes/Notes	Description
1	A-01379	Clear	END CAP,SWING HEADER,BTM LOAD,O.H.C.,204
	A-71379	Dark Bronze	END CAP,SWING HEADER,BTM LOAD,O.H.C.,313
2	T-00061		FHMS,1/4-20x1.000L.,PHIL,TRI-LOBE,ZINC
3	C-00067		NAMEPLATE,NABCO LOGO
4	M-01040		CONTROL BOX MOUNT
5	M-01457	Assembly including Chasis	CONTROL BOX: 300/400
6	V-00245		RELAY,LOCK OUT,PC-6,(USSE KIT #14-11807)
7	T-00367		NUT:HEX:10-24:ZN
8	T-00199		WASHER, LOCK, EXT, #10 ID, ZINC
9	M-01488		PLATE:MOUNTING :RELAY
10	V-00052		TRANSFORMER,24 V / 40 VA.
11	T-00361		PHMS:10-24x0.375L:PHIL:SS
12	A-00347		MOTOR AND COUPLER
13	M-01072		HARNESS,POWER,MAGNUM/OPUS
14	M-01169		SWITCH,ON/OFF/HOLD ROCKER,GT LOGO
15	A-00552		SWITCH,KEY,KS-14,3 POSITION
16	A-00449		SWITCH,ROCKERLE RS-11,ON/OFF,ASSY W/FPLT
17	M-01374	Clear	OHC,SINGLE STRIKE BASE,3-1/4"
	M-71374	Dark Bronze	OHC,SINGLE STRIKE BASE,3-1/4"
18	M-01177		LOCK COVER PLATE - BOTTOM
19	T-00391		"FHMS,10-24x0.750L.,PHIL,ZINC"
20	21-1590	Clear/no Finger Guard	OHC TOP PIVOT & BASE ASSY NO FG,204
	21-1591	Dark Bronze/no Finger Guard	OHC TOP PIVOT & BASE ASSY NO FG,313
	A-00560	Clear/Finger Guard	OHC TOP PIVOT & BASE ASSY FG,204
	A-70560	Dark Bronze/Finger Guard	OHC TOP PIVOT & BASE ASSY FG,313
21	A-00698	RH	"OPERATOR,SWINGER,RH,ANALOG"
	A-00699	LH	"OPERATOR,SWINGER,LH,ANALOG"
22	A-00347		MOTOR AND COUPLER
23	T-00103		"SHCS,10-24x0.875L.,W-LOCK PATCH"
24	A-00352		HARNESS,THREE SWITCH OPERATOR
25	A-00551		OPERATOR HOUSING ASM,PE
26	T-00238		FHMS,10-24x1.000L.,PHIL,ZINC
27	A-00348		COVER,SWITCH,SWINGER
28	M-01018		BUMPON STRIP
29	A-00501		BRKT.;MOTOR;REAR;BTM.LOAD
30	T-00067		NUT,HEX,JAM,3/8-16,ZINC
31	T-00092		WASHER,.438 ID,1.00 OD,.083 THK,ZINC
32	T-00073		SHSS,1/4-20x0.500L.,KNURL PT.
33	A-00737		"SOFT START KIT,SWINGER"
	A-00955		"SUPER SOFT START KIT,SWINGER"
34	A-61176	Clear	"FILLER CHANNEL;HINGE STILE;5-15/32,204"
	A-71176	Dark Bronze	"FILLER CHANNEL;HINGE STILE;5-15/32,313"

Analog Bottom Load Header			
Item	Part	Finish/Sizes/Notes	Description
35	M-60897	Clear	CHANNEL,SNAP IN,204,,EXTRU
	M-70897	Dark Bronze	CHANNEL,SNAP IN,313,EXTRU
36	M-01085		HARNESS, POWER SWITCH - SWINGERS/710
37	V-00283		SPACER,CIRCUIT BOARD,STANDOFF
38	A-00643		DOOR STOP:NON PANIC
39	T-00232		SHCS,10-24x0.875L.,ZINC
40	T-00231		WASHER, LOCK, SPLIT, #10 ID, ZINC
41	A-00430		KIT,PANIC LATCH,O.H.C.204
	A-70430		KIT,PANIC LATCH,O.H.C.,313
42	T-00064		HHCS,1/4-20x0.750L.,ZINC
43	T-00087		WASHER, LOCK, EXT, 1/4 ID, ZINC
44	M-01181		TOP FRAME MOUNT, SUB - ASSY - SWINGER
45	V-00098		SADDLE, WIRE
46	A-01185	Sold as an Option	XFMR;24V;40A;W-MTG.BKT.& HDW.
47	V-00104		WASHER, CUP.312 ID X .88 OD X .040 THICK
48	M-00450		SPACER,MTG.END CAP
49	T-00346		HHCS:1/4-20x0.375L:GREEN:WASH HD:SLOT
50	T-00047		NUT,WIRE,72B,2-18AWG-3-16AWG
51	A-00409		PARTS BAG,ON/OFF,SWINGER,SWITCH

# SERVICE PARTS: OHC OPUS SIDE LOAD HEADER



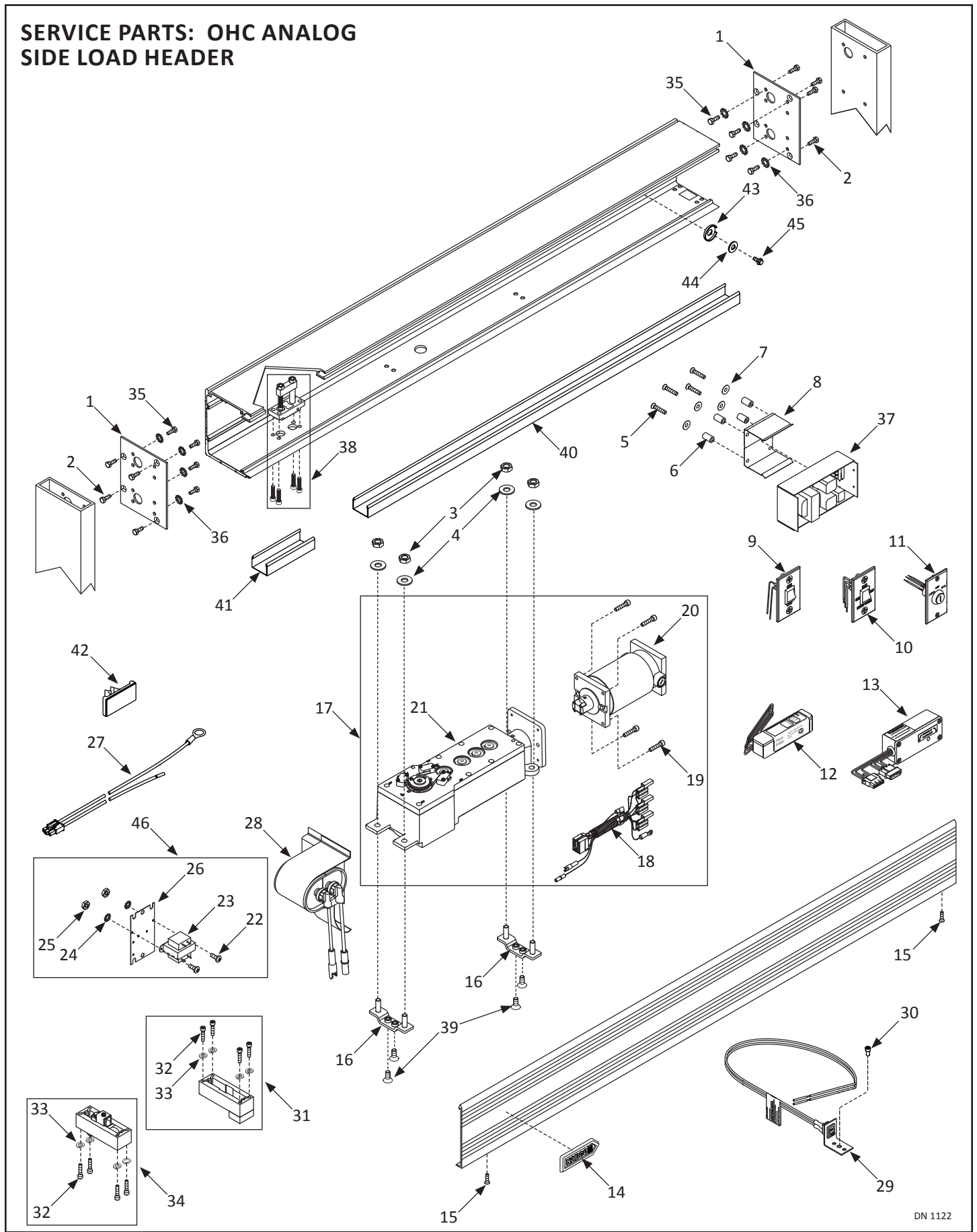
DN 1115

Opus Side Load Header			
Item	Part	Finish/Sizes/Notes	Description
1	M-61172	Clear	END CAP,SIDELOAD,OHC,2 ACCESS HOLES,204
	M-71172	Dark Bronze	END CAP,SIDELOAD,OHC,2 ACCESS HOLES,313
2	T-00016	Clear	FHMS,1/4-20x0.438L.,PHIL,UNDERCUT,ZINC
	T-00108	Dark Bronze	FHMS,1/4-20x0.438L.,PHIL,UNDERCUT,BLK ZN
3	T-00064		HHCS,1/4-20x0.750L.,ZINC
4	T-00087		WASHER, LOCK, EXT, 1/4 ID, ZINC
5	A-00490		PIVOT,TOP,SWINGER
6	T-00067		NUT,HEX,JAM,3/8-16,ZINC
7	T-00092		WASHER,.438 ID,1.00 OD,.083 THK,ZINC
8	T-00185		SHCS,10-24x0.500L.,BK.OX.
9	T-00365		WASHER,.170 ID,.625 OD,.032 THK,NYLON
10	M-01175		HARNESS,MOTOR,BRAKE MODULE,SWINGER
11	M-01546		CONTROLLER,OPUS
12	T-00335		SHCS,10-24x0.313L.,ZINC
13	V-00288	Used on Break Module	FUSE,3 AMP,250V,FAST,2AG,AXIAL LEAD
	V-00552	Used on Opus Control	FUSE;5A;GMA;5X20mm
14	A-01091	RH	"OPER.SWGR,W/ENCOD,ROF;RH;NO CLUTCH;S-LO
	A-01090	LH	"OPER.SWGR,W/ENCOD.ROF;LH;NO CLUTCH;S-LO
15	T-00197		NUT,WIRE,RANGE 22-14AWG,GREY
16	T-00031		FHMS,10-32x0.500L.,PHIL,UCUT,T-LOBE,BKZN
17	A-00805		SWITCH,ROCKER,SWINGER,ON/OFF/HOLD OPEN
18	A-01001		HARNESS,HANDING,OPUS
19	A-01000	Not used on GT710/8710	HARNESS,MOTOR,OPUS
20	M-01043		BRACKET, OPERATOR, SIDELOAD HEADER
21	T-00334	Clear	FHMS:5/16-18x0.750L.:SOKT:ZN
	T-00370	Dark Bronze	FHMS:5/16-18x0.750L.:SOKT:BK.ZN
22	T-00337		PHSMS:#8x0.625L.:PHIL
23	M-01085		HARNESS, POWER SWITCH - SWINGERS/710
24	T-00232		SHCS,10-24x0.875L.,ZINC
25	C-00067		NAMEPLATE,NABCO LOGO
26	A-00643		DOOR STOP:NON PANIC
27	T-00231		WASHER, LOCK, SPLIT, #10 ID, ZINC
28	A-00430		KIT,PANIC LATCH,O.H.C.204
29	M-01072		HARNESS,POWER,MAGNUM/OPUS
30	V-00098		SADDLE, WIRE
31	M-60889	Clear/Cut to length	SNAP CHANNEL, GT8000,204,,EXTRU
	M-70889	Dark Bronze/Cut to length	SNAP CHANNEL, GT8000,313,EXTRU
32	M-01303	Clear/With Finger Guard	SNAP IN,CHANNEL,204,W-FG
	M-71303	Dark Bronze/With Finger Guard	SNAP IN,CHANNEL,313,W-FG
	M-01302	Clear/No Finger Guard	SNAP IN,CHANNEL,204,NO-FG
	M-71302	Dark Bronze/No Finger Guard	SNAP IN,CHANNEL,313,NO-FG
33	M-01680	Simultaneous Pair	HARNESS,SIM PAIR,OPUS

Opus Side Load Header			
Item	Part	Finish/Sizes/Notes	Description
34	A-00824	RH	"OPERATOR,SWGR,W/ENCODER, RH CLUTCHLESS"
	A-00823	LH	"OPERATOR,SWGR,W/ENCODER, LH CLUTCHLESS"
35	A-01053	RH	"OPER. SWINGER,W/O MTR.,NO CLUTCH,RH;ROF
	A-01052	LH	"OPER. SWINGER,W/O MTR.,NO CLUTCH,LH;ROF
36	V-00090		MOTOR,SHORT FRAME,ENCODER,DUOWEI
37	T-00103		"SHCS,10-24x0.875L.,W-LOCK PATCH"
38	A-00620		GROUND WIRE:SWING OPERATOR:MAGNUM
39	A-01002	Not used on GT710/8710	HARNESS,ADAPTER,NON-ENCODER,OPUS
40	V-00104		WASHER, CUP.312 ID X .88 OD X .040 THICK
41	T-00029		WASHER,.250 ID,.563 OD,.049 THK,ZINC
42	T-00347		HHCS:10-32x0.375L:GREEN:WASH HD:SLOT
43	M-01576		SWITCHPLATE,ON/OFF/HOLD OPEN
44	A-00888		CONTROLLER,W/ BRAKE,SIDELOAD,OPUS



# SERVICE PARTS: OHC ANALOG SIDE LOAD HEADER

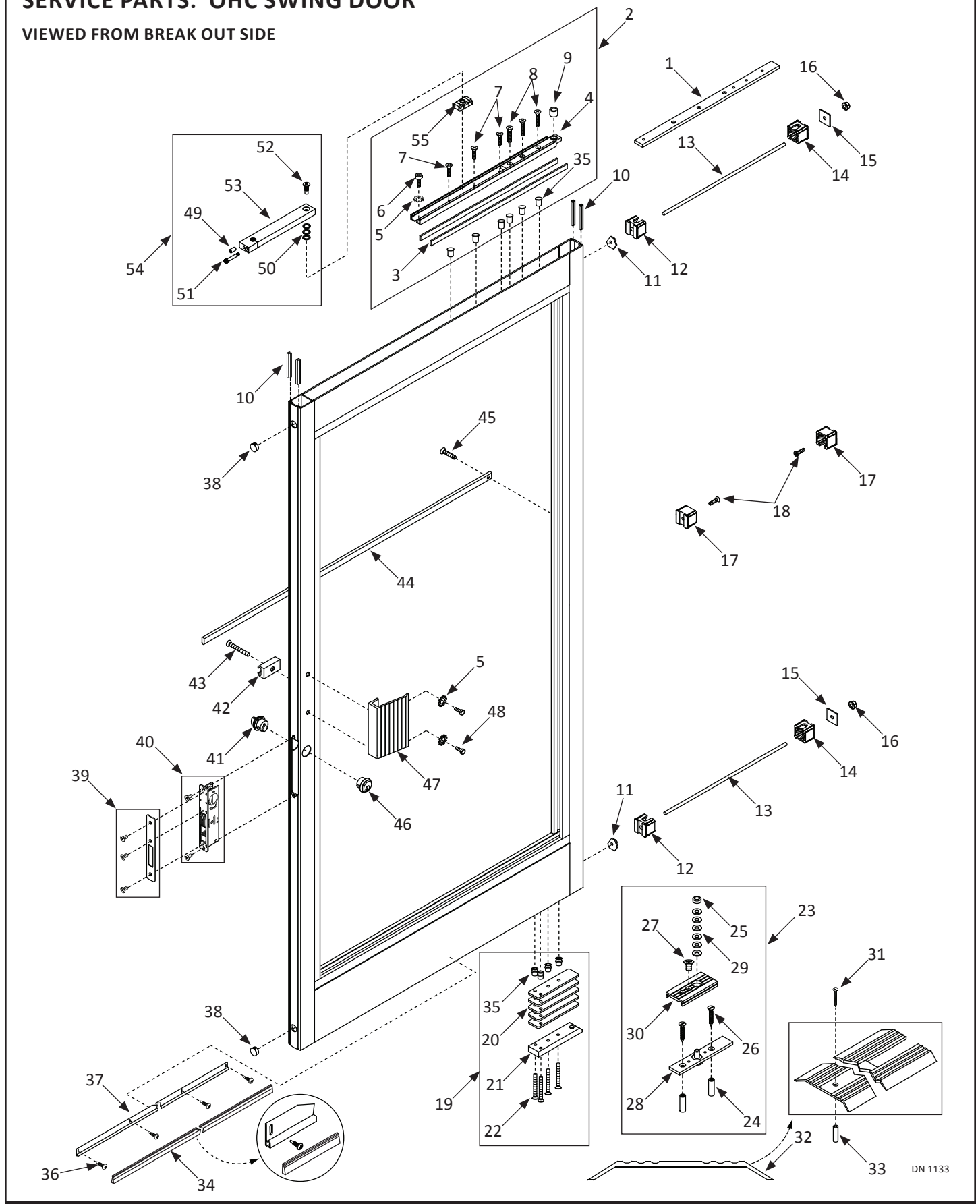


Analog Side Load Header			
Item	Part	Finish/Sizes/Notes	Description
1	M-61172	Clear	END CAP,SIDELOAD,OHC,2 ACCESS HOLES,204
	M-71172	Dark Bronze	END CAP,SIDELOAD,OHC,2 ACCESS HOLES,313
2	T-00016	Zinc	FHMS,1/4-20x0.438L.,PHIL,UNDERCUT,ZINC
	T-00108	Black Onix	FHMS,1/4-20x0.438L.,PHIL,UNDERCUT,BLK ZN
3	T-00067		NUT,HEX,JAM,3/8-16,ZINC
4	T-00092		WASHER,.438 ID,1.00 OD,.083 THK,ZINC
5	T-00238		FHMS,10-24x1.000L.,PHIL,ZINC
6	V-00283		SPACER,CIRCUIT BOARD,STANDOFF
7	T-00365		WASHER,.170 ID,.625 OD,.032 THK,NYLON
8	A-00957		CONTROL BOX MOUNT
9	A-00449		SWITCH,ROCKERLE RS-11,ON/OFF,ASSY W/FPLT
10	M-01169		SWITCH,ON/OFF/HOLD ROCKER,GT LOGO
11	A-00552		SWITCH,KEY,KS-14,3 POSITION
12	V-00245		RELAY,LOCK OUT,PC-6,(USSE KIT #14-11807)
13	A-00592		MODULE:TIME DELAY: ASM W/ CLIP
14	C-00067		NAMEPLATE,NABCO LOGO
15	T-00337		PHSMS:#8x0.625L.:PHIL
16	M-01043		BRACKET, OPERATOR, SIDELOAD HEADER
17	A-00698	RH	"OPERATOR,SWINGER,RH,ANALOG"
	A-00699	LH	"OPERATOR,SWINGER,LH,ANALOG"
18	A-00352		HARNESS,THREE SWITCH OPERATOR
19	T-00103		"SHCS,10-24x0.875L.,W-LOCK PATCH"
20	A-00347		MOTOR AND COUPLER
21	A-00551		OPERATOR HOUSING ASM,PE
22	T-00361		PHMS:10-24x0.375L:PHIL:SS
23	V-00052		TRANSFORMER,24 V / 40 VA.
24	T-00199		WASHER, LOCK, EXT, #10 ID, ZINC
25	T-00367		NUT:HEX:10-24:ZN
26	M-01488		PLATE:MOUNTING :RELAY
27	M-01072		HARNESS,POWER,MAGNUM/OPUS
28	A-00737		"SOFT START KIT,SWINGER"
	A-00955		"SUPER SOFT START KIT,SWINGER"
29	M-01085		HARNESS, POWER SWITCH - SWINGERS/710
30	T-00335		SHCS,10-24x0.313L.,ZINC
31	A-00643		DOOR STOP:NON PANIC
32	T-00232		SHCS,10-24x0.875L.,ZINC
33	T-00231		WASHER, LOCK, SPLIT, #10 ID, ZINC
34	A-00430		KIT,PANIC LATCH,O.H.C.204
	A-70430		KIT,PANIC LATCH,O.H.C.,313
35	T-00064		HHCS,1/4-20x0.750L.,ZINC
36	T-00087		WASHER, LOCK, EXT, 1/4 ID, ZINC
37	M-01457	w/Chassis	CONTROL BOX: 300/400

Analog Side Load Header			
Item	Part	Finish/Sizes/Notes	Description
38	A-00490		PIVOT,TOP,SWINGER
39	T-00334	Zinc	FHMS:5/16-18x0.750L.:SOKT:ZN
	T-00370	Black Zinc	FHMS:5/16-18x0.750L.:SOKT:BK.ZN
40	M-60889	Clear/Cut to length	SNAP CHANNEL, GT8000,204,,EXTRU
	M-70889	Dark Bronze/Cut to length	SNAP CHANNEL, GT8000,313,EXTRU
41	M-01303	Clear/With Finger Guard	SNAP IN,CHANNEL,204,W-FG
	M-71303	Dark Bronze/With Finger Guard	SNAP IN,CHANNEL,313,W-FG
	M-01302	Clear/No Finger Guard	SNAP IN,CHANNEL,204,NO-FG
	M-71302	Dark Bronze/No Finger Guard	SNAP IN,CHANNEL,313,NO-FG
42	V-00098		SADDLE, WIRE
43	V-00104		WASHER, CUP.312 ID X .88 OD X .040 THICK
44	T-00029		WASHER,.250 ID,.563 OD,.049 THK,ZINC
45	T-00347		HHCS:10-32x0.375L:GREEN:WASH HD:SLOT
46	A-01185	Sold as an Option	XFMR;24V;40A;W-MTG.BKT.& HDW.

# SERVICE PARTS: OHC SWING DOOR

VIEWED FROM BREAK OUT SIDE



Swing Door			
Item	Part	Finish/Sizes/Notes	Description
1	A-00948	1/4" Spacer	SPACER BLOCK
	M-01342	3/8" Spacer	BLOCK - SPACER 3/8
	M-01337	3/16" Spacer	BLOCK,SPACER,3/16"
2	A-00459		PIVOT BLOCK,O.H.C.,TRACK W/STOP
3	M-01327	5/8" Web	SPACER,SIDE
4	A-00455		PIVOT BLOCK,O.H.C.,TRACK W/STOP
5	T-00087		WASHER, LOCK, EXT, 1/4 ID, ZINC
6	T-00101		"SHCS,1/4-20x1.500L.,BK.OX."
7	T-00089		FHMS,1/4-20x1.500L.,PHIL,UNDERCUT,ZINC
8	T-00172		FHMS,1/4-20x2.000L.,PHIL,ZINC
9	V-00115		BEARING, 1/2 x 3/4 x 5/8" WIDE
10	M-00499		WEATHERING:PILE:.27W X .25H:W/ ADH & FIN
11	M-00416		T-NUT, 3/8"-16, TIE ROD
12	M-00460		CLIP,MUNTIN,.500 HOLE
13	M-00272		3/8-16 THREADED ROD
14	M-00461		CLIP,MUNTIN,.386 HOLE
15	M-00422		PLATE,TIE ROD
16	T-00025		NUT,WHIZLOCK,3/8-16,ZINC
17	M-00462		CLIP,MUNTIN,.261 HOLE
18	T-00061		FHMS,1/4-20x1.000L.,PHIL,TRI-LOBE,ZINC
19	A-00500		BTTM PIVOT ASSY, DOOR PORTION, SWING DR
20	M-01053		SPACER,BASE PIVOT,OHC
21	24-0747-01		OHC - BASE PIVOT SUB-ASSY
22	T-00172		FHMS,1/4-20x2.000L.,PHIL,ZINC
23	A-00417		FLOOR PIVOT ASSY, PIN & COVER
24	T-00314		SCREW ANCHOR, #16 X 1" LG
25	M-01166		SELF ANGLER,PIVOT BASE,UL PART
26	T-00313		FHSMS - SLOTTED, #14 X 1 1/12" LG
27	T-00016		FHMS,1/4-20x0.438L.,PHIL,UNDERCUT,ZINC
28	M-01183		SHAFT,BASE PIVOT,OHL-UL PART
29	T-00312		SHIM WSHR, .437 ID X .969 OD X .032 THK
30	M-01231		PREVENTER BLOCK, DUST AND RODENT
31	24-0031-07		SCREW,SLTD FLAT HD,#10X1 1/2" TYPE A
32	24-10901		THRESHOLD SWINGER, MACHINED
33	14-6394		ANCHOR, STRT PLSTC 10-12" X 1"
34	M-00274		BRUSH, NYLON, 1" STEPPED
35	T-00048		RIVNUT,1/4-20, .027-.165 GRIP RANGE
36	T-00222	Zinc	PHSMS,6x0.500L.,PHIL,TEKS,ZINC
	T-00260	Black Zinc	PHSMS,6x0.500L. PHIL,TEKS BLK ZN
37	24-9125-01	Clear	WEATHERING EXT,204
	24-9125-02	Dark Bronze	WEATHERING EXT,313

Swing Door			
Item	Part	Finish/Sizes/Notes	Description
38	V-00720		"PLUG,HOLE,13/16 DOME""
39	V-00014	Clear	COVER,MS LOCK,W/ CUTOUT,204
	V-70014	Dark Bronze	COVER,MS LOCK,W/ CUTOUT,313
40	V-00005		LOCK, ADAMS-RITE #MS1853
41	V-00116	Clear	CYLINDER,LOCK,THUMBTURN,204
	V-70116	Dark Bronze	CYLINDER,LOCK,THUMBTURN,313
42	A-60012	Clear	"BLOCK,PILLOW,MACHINED,204"
	A-70012	Dark Bronze	PILLOW BLOCK;MACHINED;313
43	T-00031		FHMS,10-32x0.500L.,PHIL,UCUT,T-LOBE,BKZN
44	24-5475-01	Clear	PUSH BAR - MACHINED
	24-5475-02	Dark Bronze	PUSH BAR - MACHINED
45	T-00089		FHMS,1/4-20x1.500L.,PHIL,UNDERCUT,ZINC
46	V-00123	Clear	CYLINDER,LOCK,KEYED,204
	V-70123	Dark Bronze	CYLINDER,LOCK,KEYED,313
47	M-01389	Clear	PULL HANDLE,MACHINED,204
	M-71389	Dark Bronze	PULL HANDLE,MACHINED,313
48	T-00064		HHCS,1/4-20x0.750L.,ZINC
49	T-00322		SHSS,5/16-24x0.625L.,CUP PT.
50	T-00319		WASHER15/32 IDx5/8 ODx1-1/16THK
51	T-00318		BOLT,SHLDR.3/8 DIAx1.750L.
52	M-01331		PIVOT SCREW,FHSMS
53	A-60788	Clear	"ARM,SPLINED,O.H.C,204"
	A-70788	Dark Bronze	"ARM,SPLINED,O.H.C,313"
54	A-60458	Clear	"ARM,O.H.C.,N.H.,204"
	A-70458	Dark Bronze	ARM,O.H.C.,N.H.,PANIC AND NO PANIC,313
55	A-00456		SLIDE BLOCK,ASSY